

SCENICA®

l'innovazione della zanzariera



Bettio zanzariere
flyscreens



Manuale di installazione, uso e manutenzione
Installation, user and maintenance manual

SCENICA®

l'innovazione della zanzariera



GRAZIE per aver scelto SCENICA® e BETTIO.

Gentile Cliente, le facciamo i sinceri complimenti per averci premiato acquistando la nostra nuova zanzariera SCENICA®, la prima al mondo totalmente priva di binario a terra. Un grazie va anche al nostro rivenditore autorizzato che, nel consigliarle SCENICA®, ci ha ribadito lui stesso la propria fiducia nelle nostre produzioni. La soddisfazione dei nostri clienti significa per noi che mesi di ricerca e progettazione, pensando sempre alle esigenze della Sua casa, hanno dato i loro frutti. E' per questo che, non volendo lasciare davvero nulla al caso, abbiamo testato la funzionalità di SCENICA® in condizioni reali per ben 10.000 aperture/chiusure; ne abbiamo curato il design e il risultato estetico fin nei minimi particolari; abbiamo optato per dei profili assai robusti; tuttavia, nel contempo, abbiamo voluto anche puntare sulla semplicità di utilizzo del prodotto, specie della barra maniglia che, grazie ad una progettazione equilibrata sotto l'aspetto ergonomico, risulta facile da movimentare anche se impugnata fuori baricentro.

Siamo certi che la Sua scelta non andrà delusa e le ricordiamo che, per un montaggio rapido ed efficace di SCENICA®, non dovrà fare altro che seguire puntualmente le istruzioni riportate nelle pagine seguenti. Semplici e accuratamente illustrate, appositamente studiate sia per il professionista sia per chi non ha dimestichezza con le zanzariere, la accompagneranno passo dopo passo nell'installazione di SCENICA®. In più le istruzioni d'uso e manutenzione e le normative CE sulla sicurezza saranno un ulteriore strumento per una lunga vita della Sua zanzariera.

Il Gruppo BETTIO Le augura pertanto un'estate serena e libera da insetti tra le mura della Sua casa.



SCENICA® the flyscreen innovation

THANK YOU for your choice of SCENICA® and BETTIO.

Dear Customer, our sincere congratulations since you rewarded us by purchasing our brand new flyscreen model SCENICA®, first in the world totally free of bottom rail. Our thanks also to our official retailer who has reasserted his own confidence in our productions when recommended you SCENICA®. The satisfaction of our customers means that many months of research and planning bore fruit – always thinking to Your home needs.

This is the reason why we didn't want to leave anything to chance and then have been testing all the practical qualities of SCENICA® for 10.000 cycles; we have taken great care over design and aesthetic results down to the smallest detail; we have chosen very strong aluminum profiles. But in the meantime, we also wanted to count on the simplicity in using the product, specially the handle-bar that, thanks to a well balanced planning, is easy to move though you handle it out of baycentre. We are sure that Your choice won't be disappointed and remind you that, for a fast and good installation of SCENICA®, you will have only to strictly follow the instructions in the next pages. Simple and precisely illustrated, expressly studied for both the professional installer and the people not familiar with flyscreens, the instructions will lead You step by step during the installation of SCENICA®. Moreover, the use and maintenance instructions and the CE rules on safety will be a further tool for a long life of Your screen.

Therefore BETTIO Group wish you a happy summertime free of insects at home.

Bettio international patent!



Consultate anche le istruzioni video on-line
See also the video on-line instructions

www.bettio.it/areatecnica



INDICE



Scenica® ad 1 battente

Pg. 4-22



Installazioni opzionali
1 battente

Pg. 23-25



Scenica® a 2 battenti

Pg. 26-30



Installazioni opzionali
2 battenti

Pg. 31-32



Scenica® incasso

Pg. 33-38



Problemi e soluzioni

Pg. 39-45



Manutenzione

Pg. 46-49



Sicurezza e normative

Pg. 50-59



CONTENTS



Scenica® one leaf

Pg. 4-22



*Optional installations
one leaf*

Pg. 23-25



Scenica® two leaves

Pg. 26-30



*Optional installations
two leaves*

Pg. 31-32



Scenica® built-in-guide

Pg. 33-38



Problems and solutions

Pg. 39-45



Maintenance

Pg. 46-49



Safety and CE rules

Pg. 50-59

Versione ad un battente
One leaf version

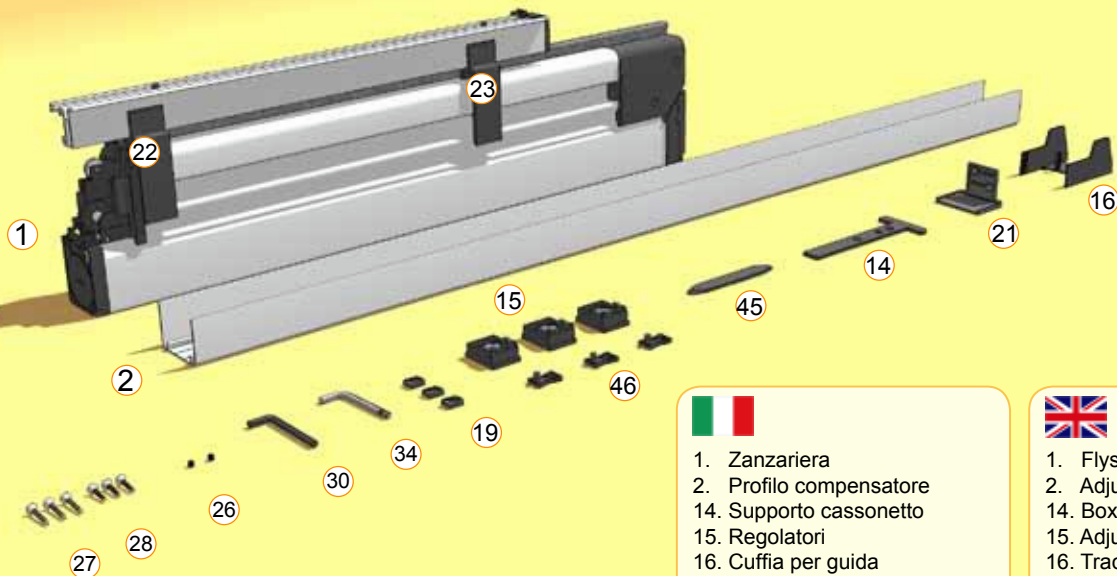

**BREVETTO
INTERNAZIONALE
BETTIO**

**BETTIO
INTERNATIONAL
PATENT**



1. Zanzariera
2. Profilo compensatore
14. Supporto cassonetto
15. Regolatori
16. Cuffia per guida
19. Tappi per profilo di riscontro
21. Tappo compensatore
22. Ferma Guida Inferiore
23. Ferma Guida Superiore
26. Viti STEI M 5x6
27. Viti TBL TX15 4x19,3
28. Viti TBL TX15 4x14
30. Chiave esagonale 2,5mm
34. Chiave Torx T15
45. Piastrina pavimento
46. Tappi regolatore



1. Flyscreen
2. Adjuster profile
14. Box support
15. Adjusters
16. Track side cap
19. Closing profile caps
21. Adjuster end caps
22. Lower Peg
23. Upper Peg
26. STEI M 5x6 screws
27. TBL TX15 4x19,3 screws
28. TBL TX15 4x14 screws
30. Hexagonal key 2,5mm
34. Torx T15 key
45. Floor plate
46. Adjuster caps



Non manomettere alcuna delle viti, se non espressamente indicato nel manuale. Pena decadenza della garanzia!



Do not loosen any screws except where expressly indicated, otherwise the warranty will decay!

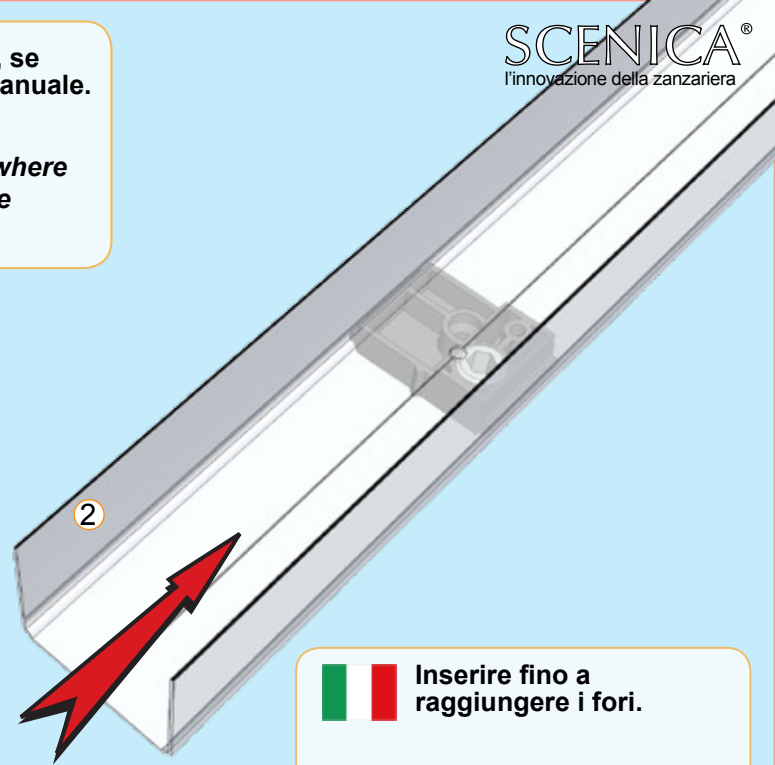

Inserire fino a raggiungere i fori.



Insert to reach the holes.



Verso il lato cassonetto.



Towards the box side.

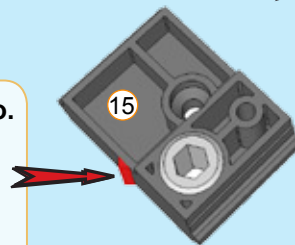

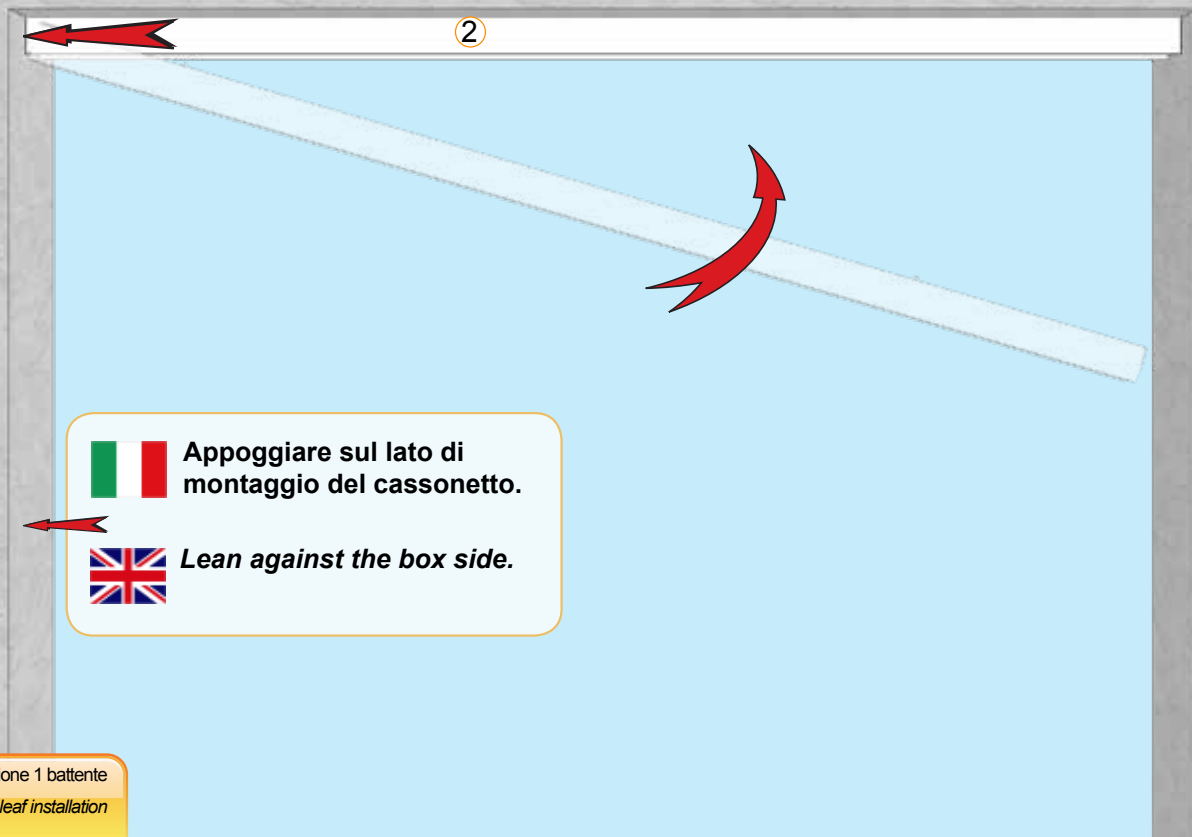



In assenza di appoggio alla parete utilizzare il tappo compensatore.



If you can't lean the profiles against the wall, please use the adjuster caps.

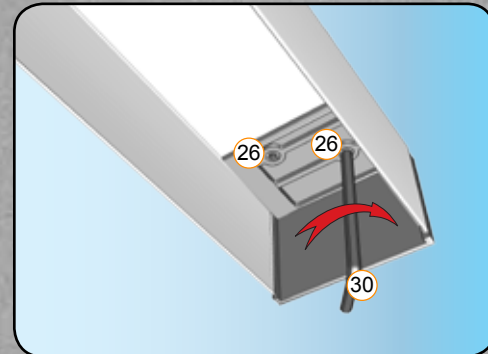
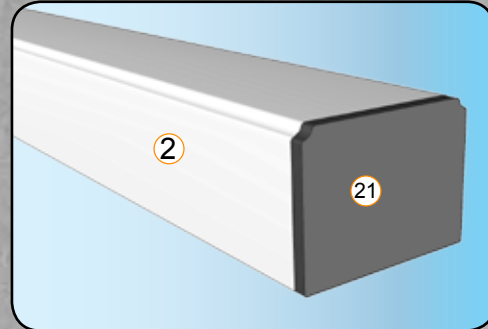
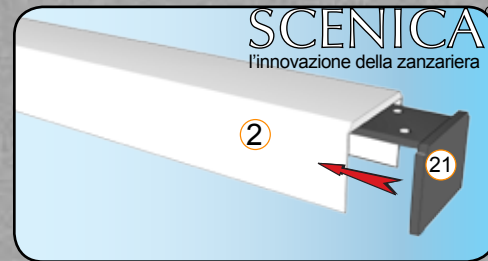

SCENICA®
l'innovazione della zanzariera

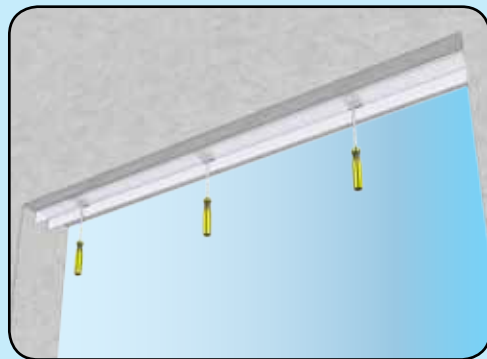
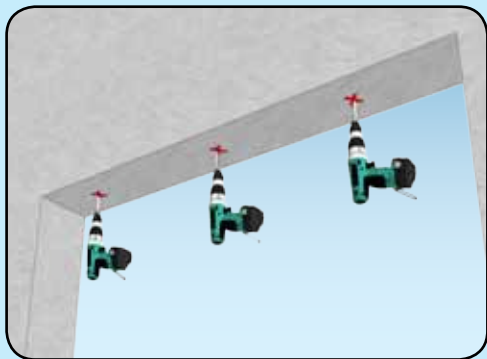
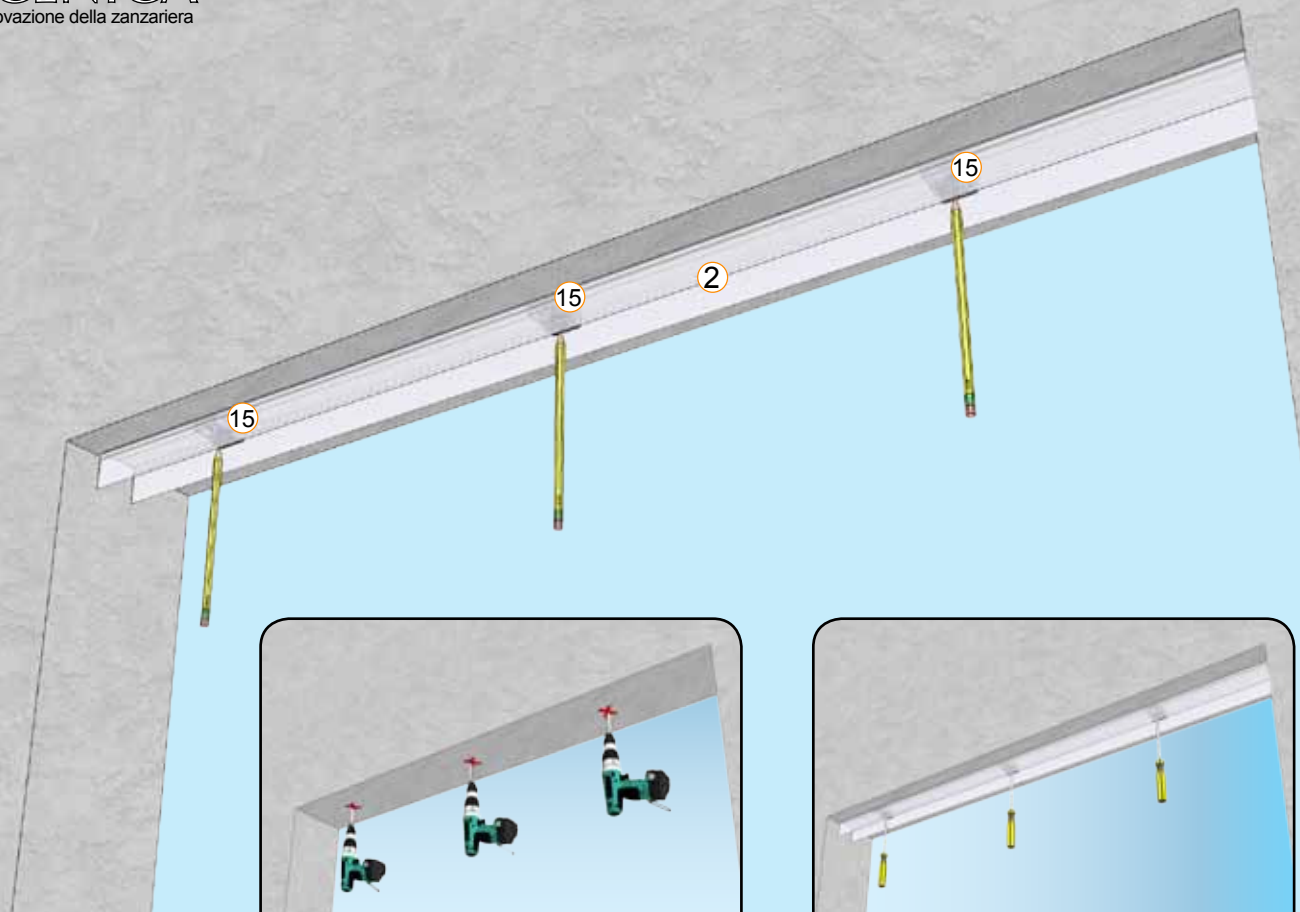

Installazione 1 battente

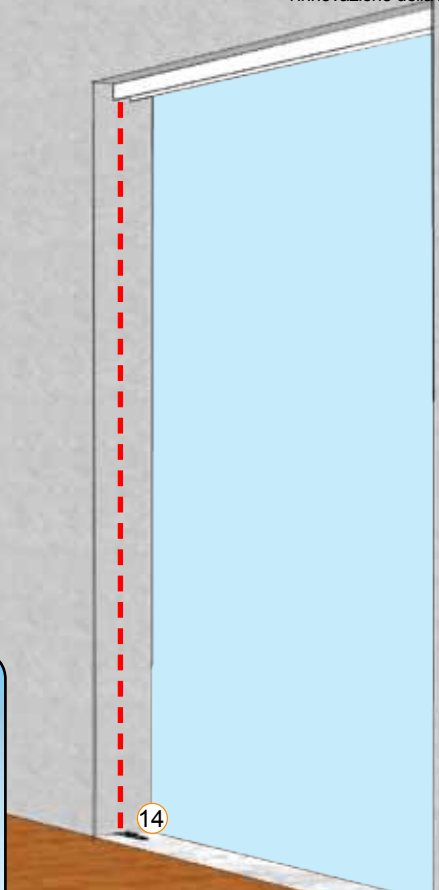
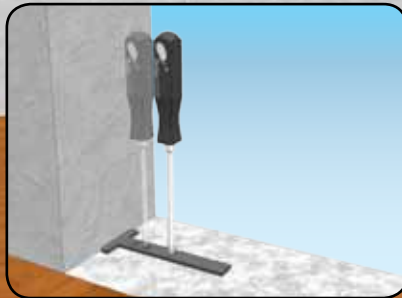
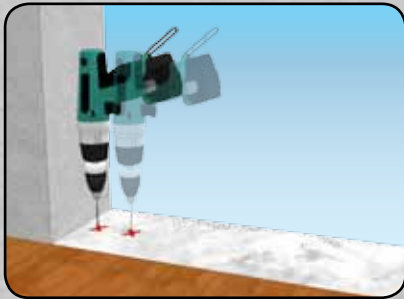
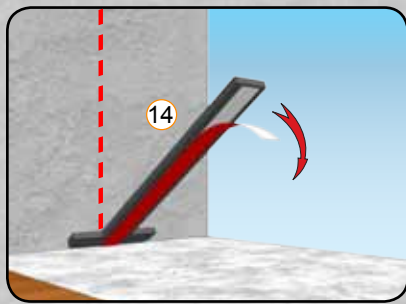

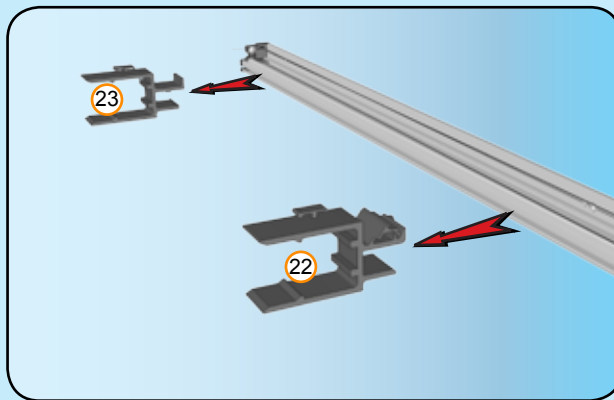
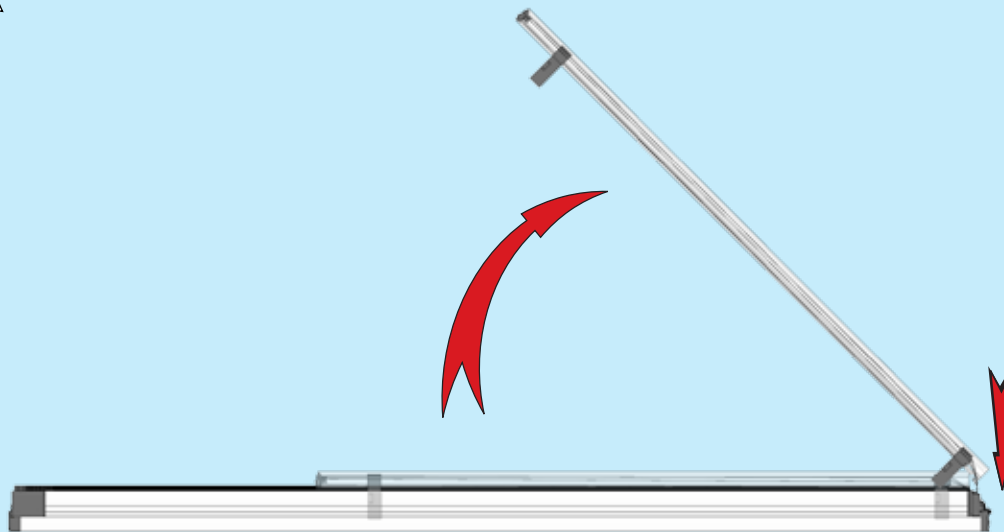

Conservare i pezzi n. 22
e 23 in caso il prodotto
debba essere imballato
nuovamente.



*Please, retain pcs. n.22
and 23 in case you have to
package again the product.*

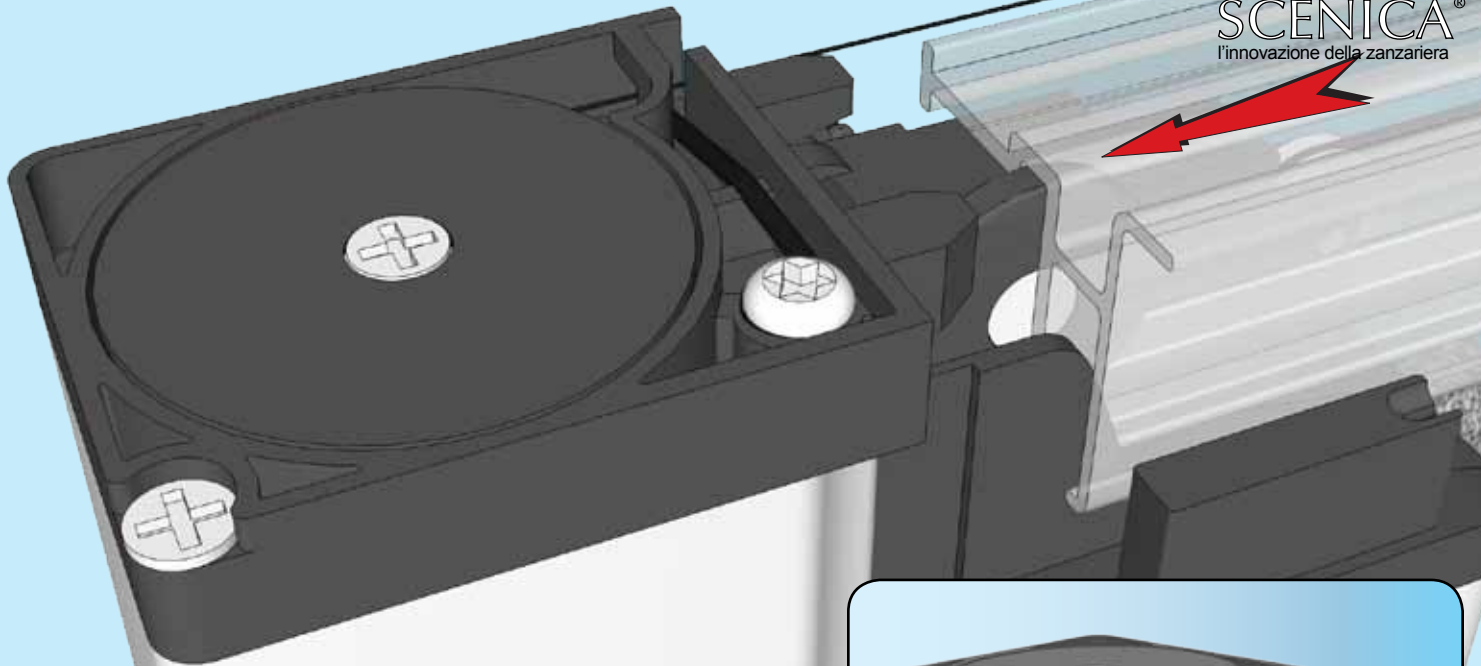

Inserire la guida facendo passare la ruota nera nell'apposita sede.



Insert the guide by making the black wheel pass inside its own housing.



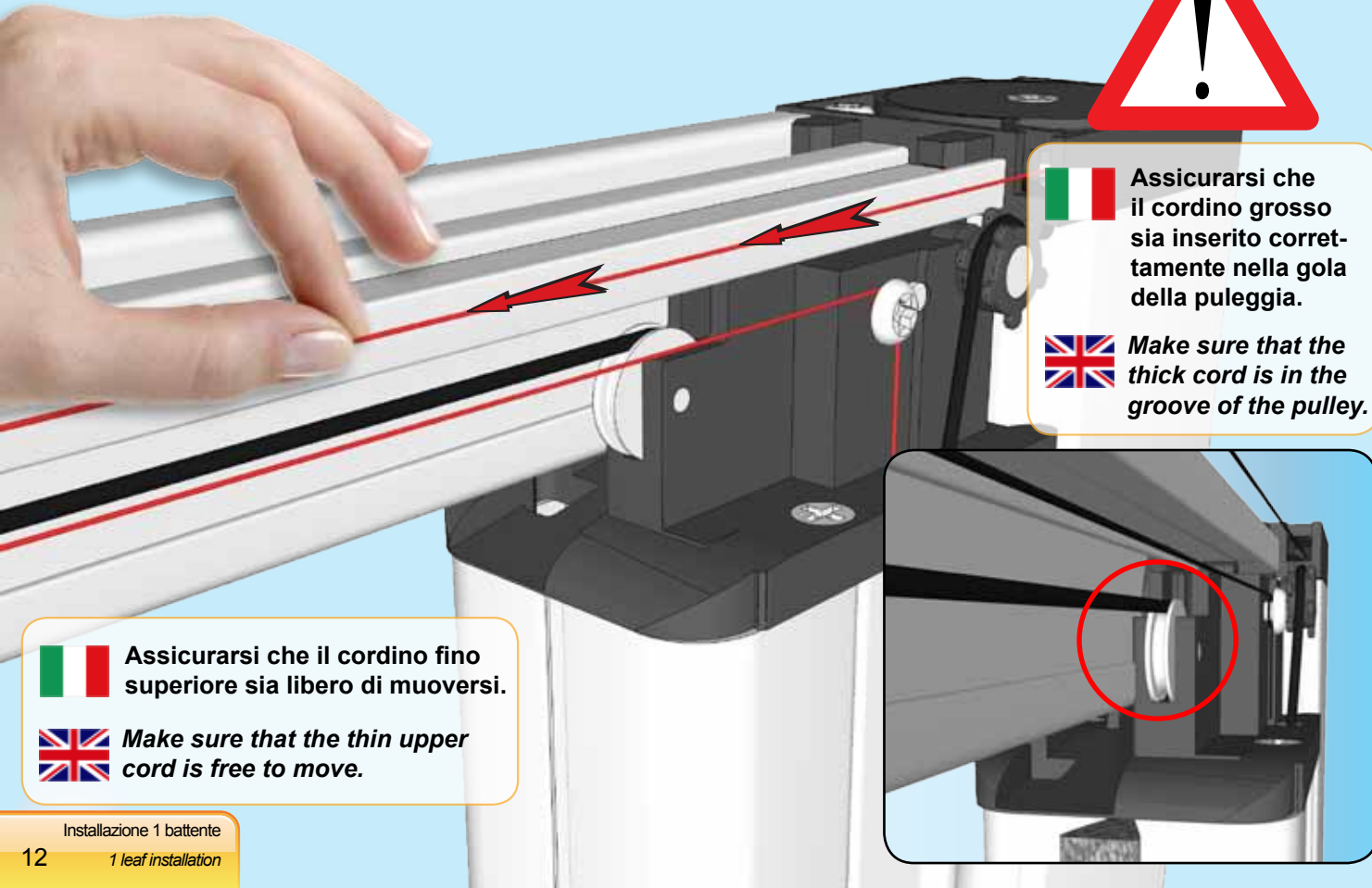



 Assicurarsi che il cordino grosso sia inserito correttamente nella gola della puleggia.

 *Make sure that the thick cord is in the groove of the pulley.*

 Assicurarsi che il cordino fino superiore sia libero di muoversi.

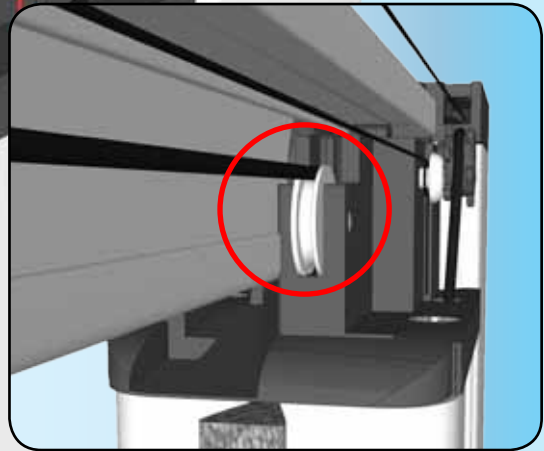
 *Make sure that the thin upper cord is free to move.*



 **Attenzione!** La parte eccedente del filo può essere tagliata soltanto dopo aver effettuato tutte le regolazioni. Si consiglia di lasciare almeno 5cm di filo per eventuali future regolazioni.

 **Attention!** Cut the wire in excess only after the whole adjustments. We suggest you to leave at least 5cm for further adjustments in the future.

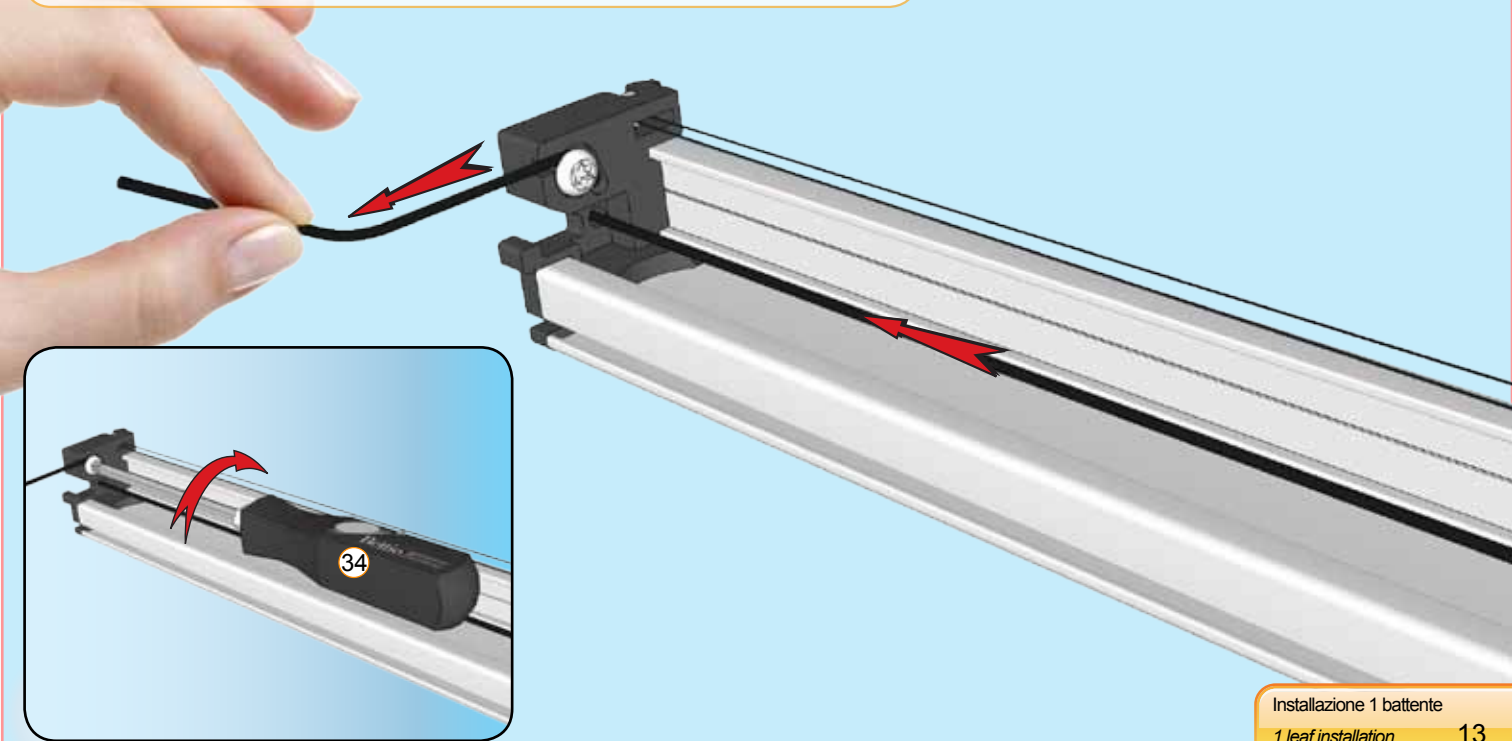

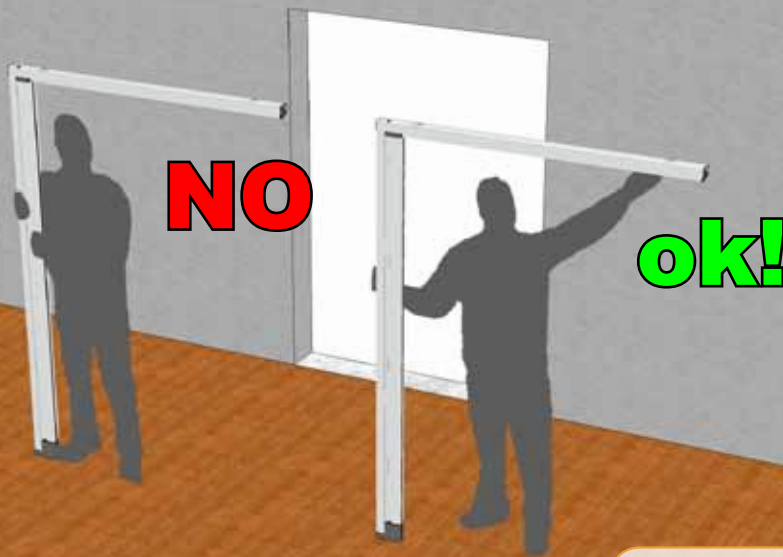

Accompagnare sempre la guida durante il trasporto!



Caution: hold the rail during the installation!

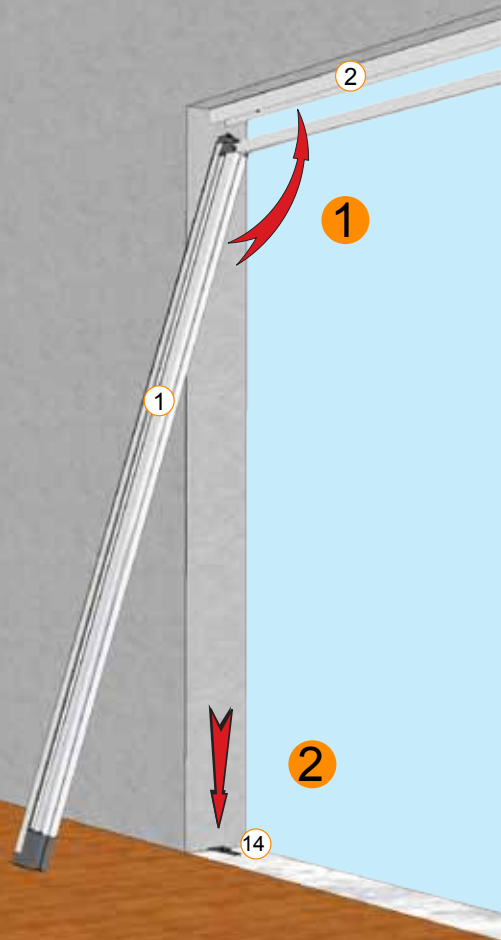

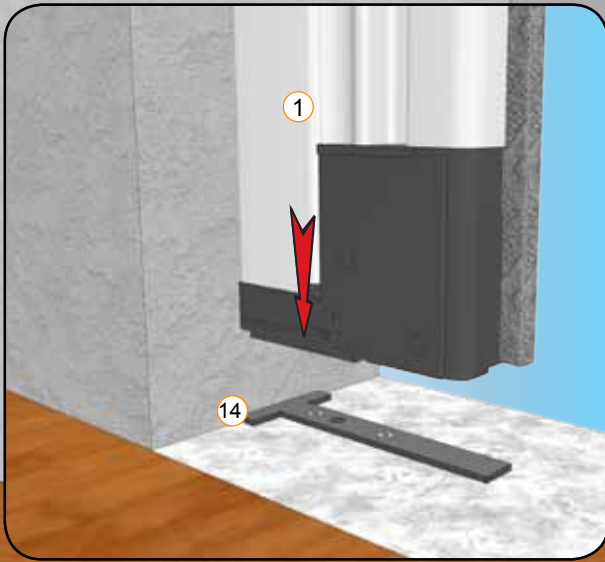

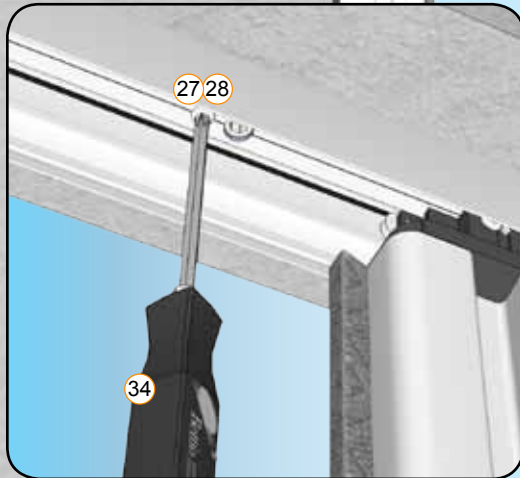

Viti per compensazioni:



28

Compensazioni inferiori a 4mm



27

Compensazioni uguali o superiori a 4mm (max 8mm)



Screws for adjustment:



28

Adjustment up to 4mm



27

Adjustment equal or over 4mm (max 8mm)

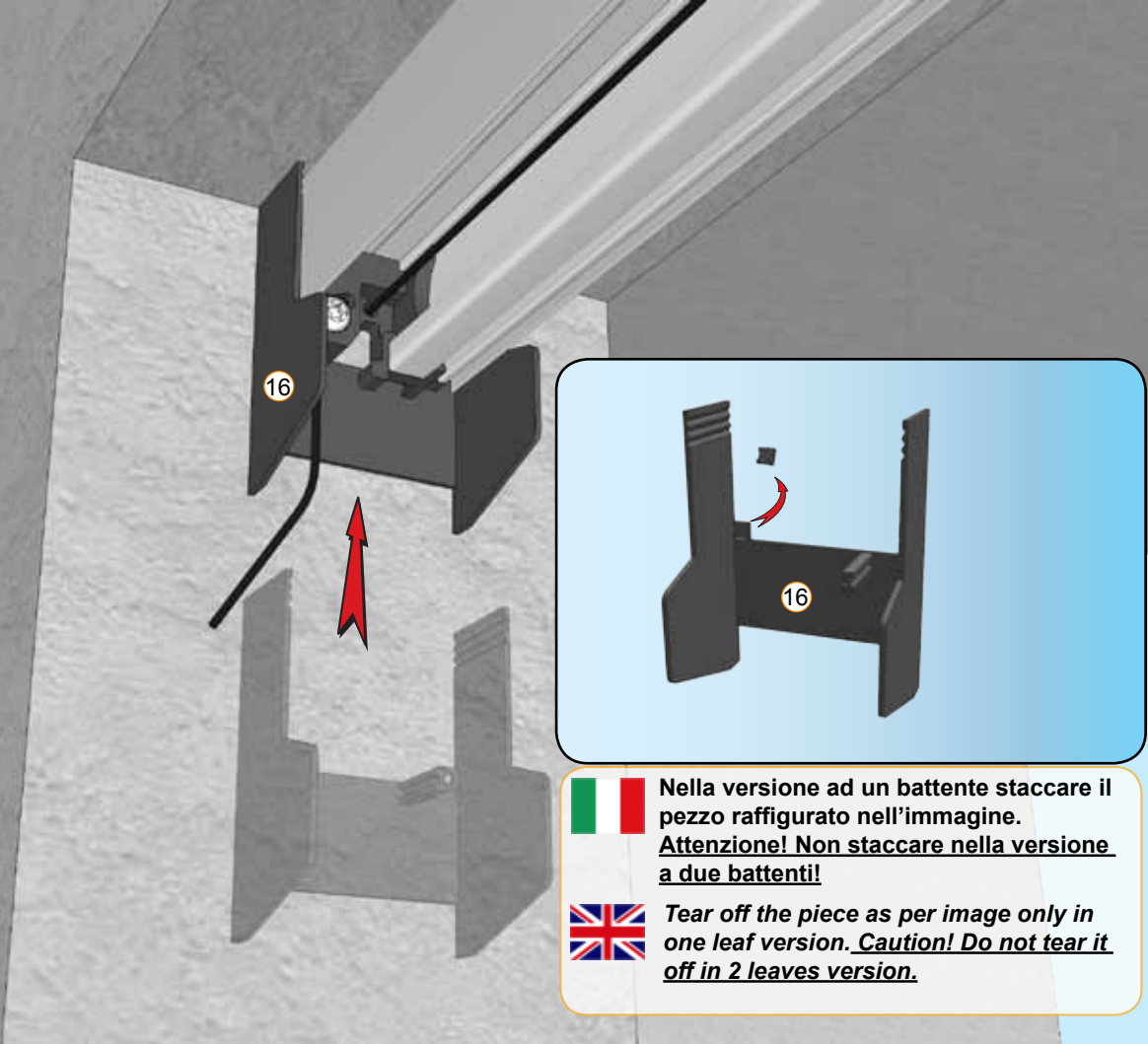

Nella versione ad un battente staccare il pezzo raffigurato nell'immagine. **Attenzione! Non staccare nella versione a due battenti!**



*Tear off the piece as per image only in one leaf version. **Caution! Do not tear it off in 2 leaves version.***



46

 Lubrificare i lati della guida mobile con lo Speciale Lubrificante per prodotti Scenica® Bettio. Per ulteriori informazioni vedi pg. 47.

 *Lubricate the sliding rail sides by using the special lubricant for Scenica® items Bettio. For further information please refer to page 47.*

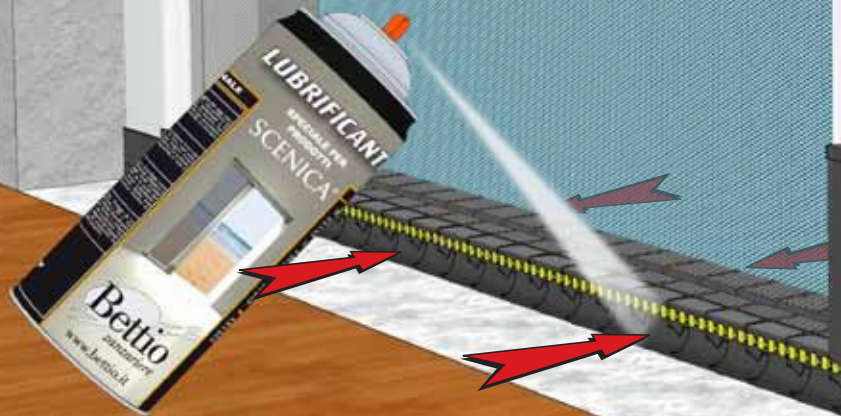

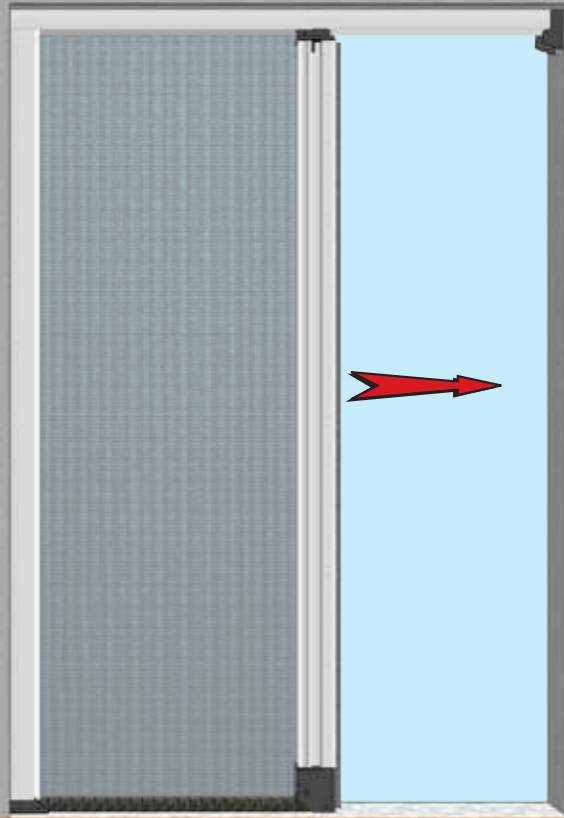



ok!

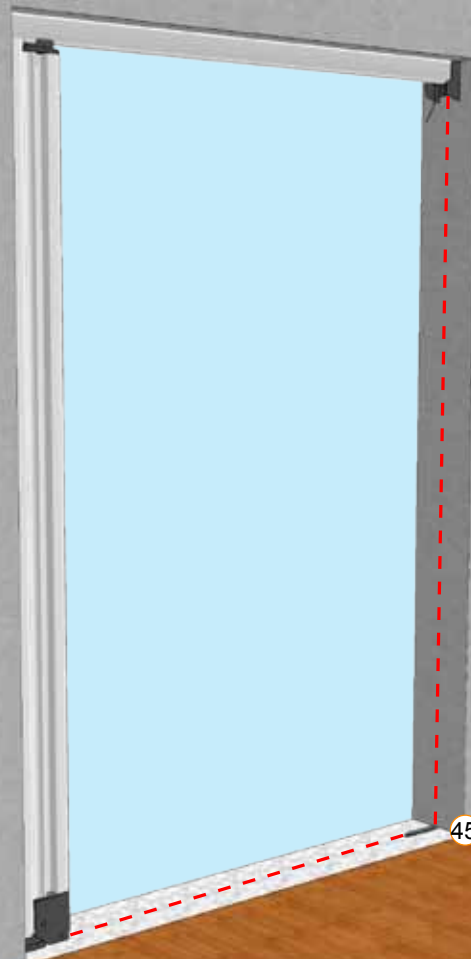
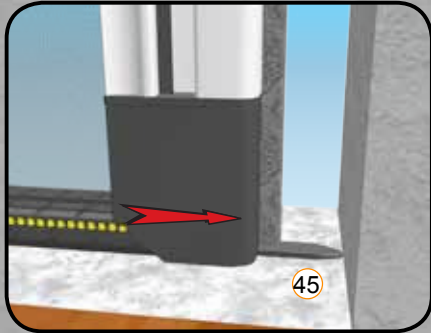
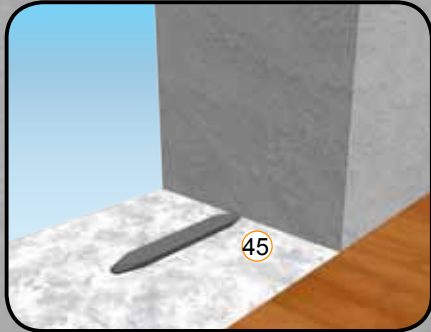
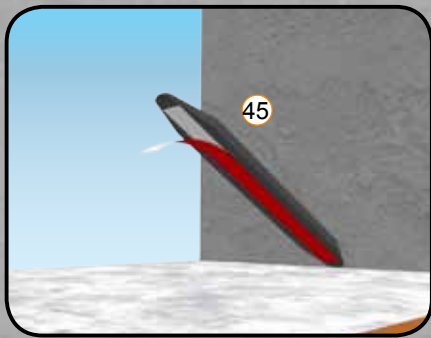



Accessorio complementare. Installazione a discrezione. L'accessorio può essere accorciato se necessario.

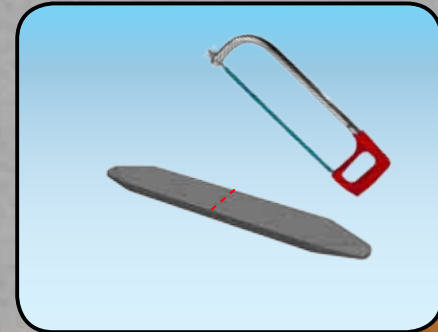

Additional component. Optional installation. The accessory can be shortened if necessary.

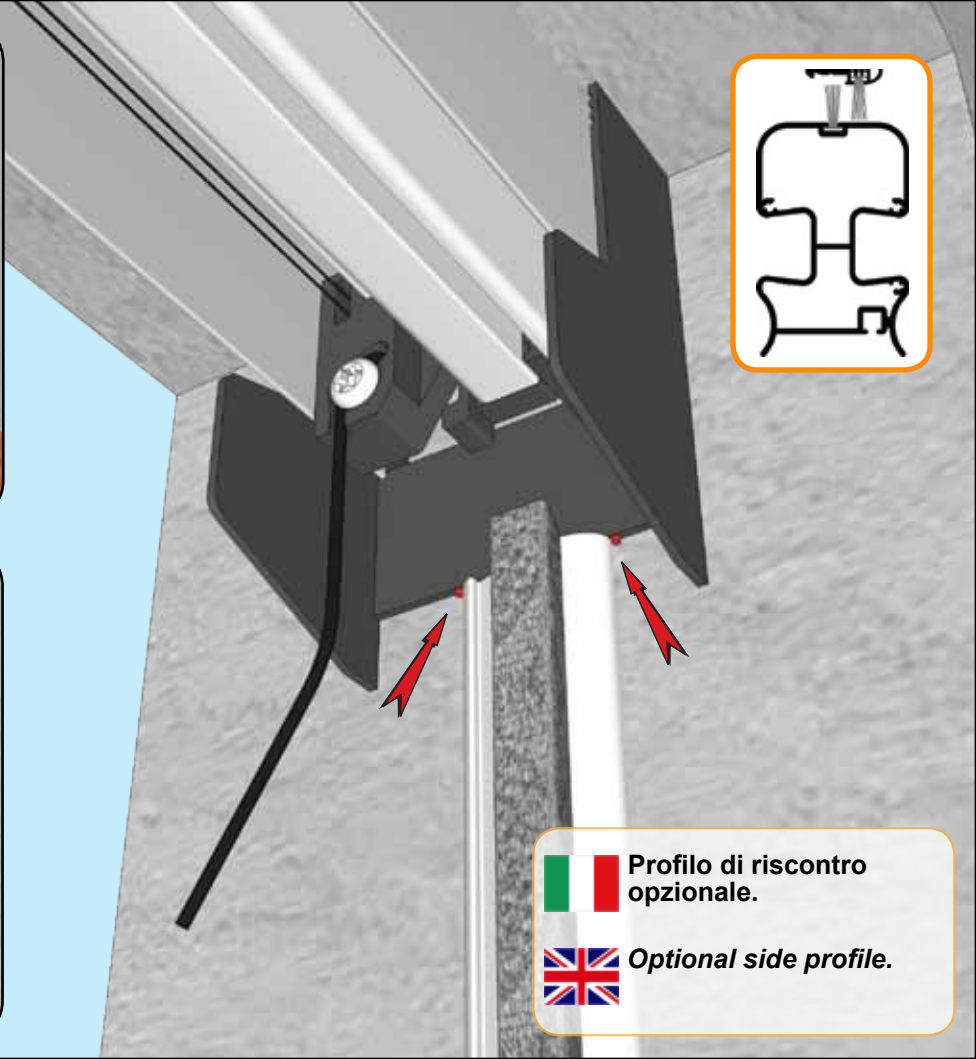
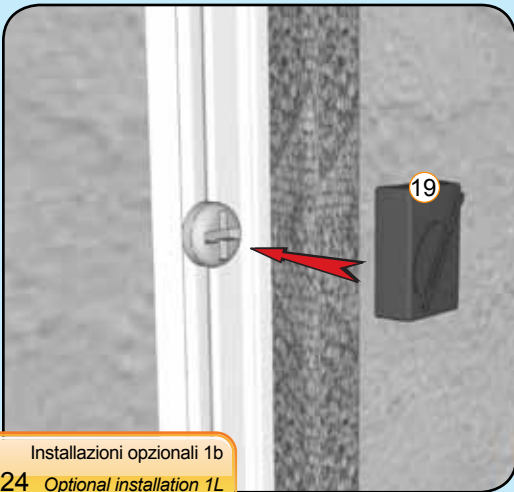
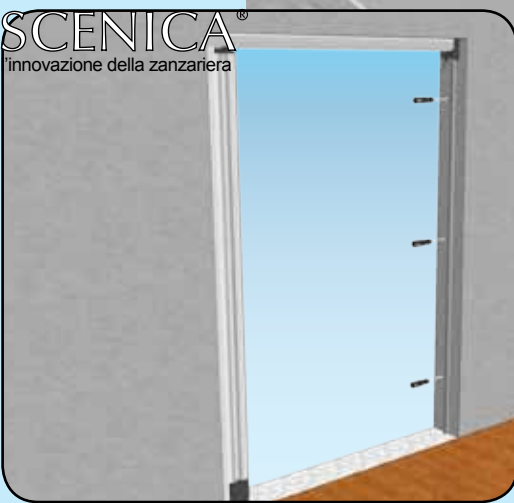



 **Profilo di riscontro
opzionale.**

 **Optional side profile.**

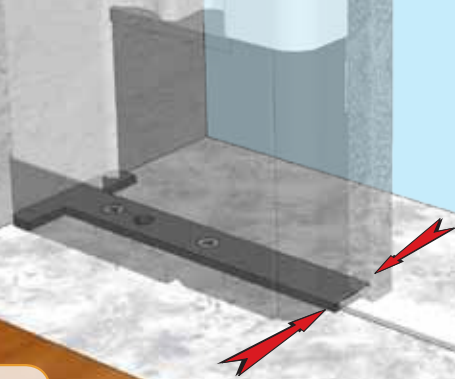
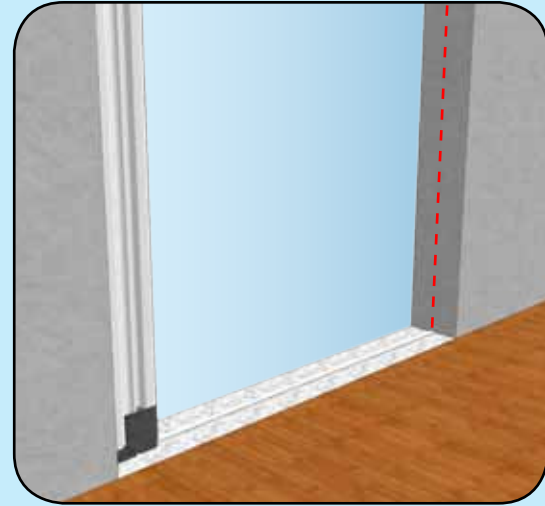
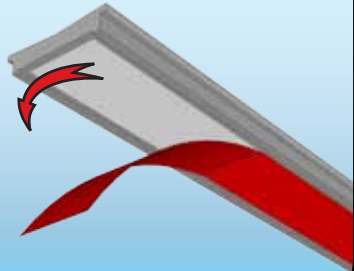

**Profilo di scorrimento
opzionale.**



Optional sliding profile.

Installazioni opzionali 1b

Optional installation 1L 25

Versione a due battenti
Two leaves version

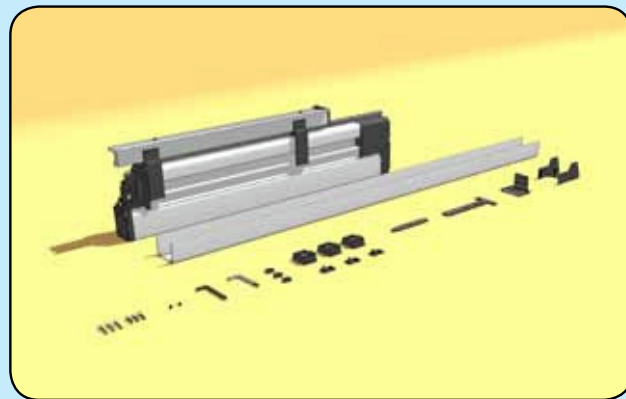
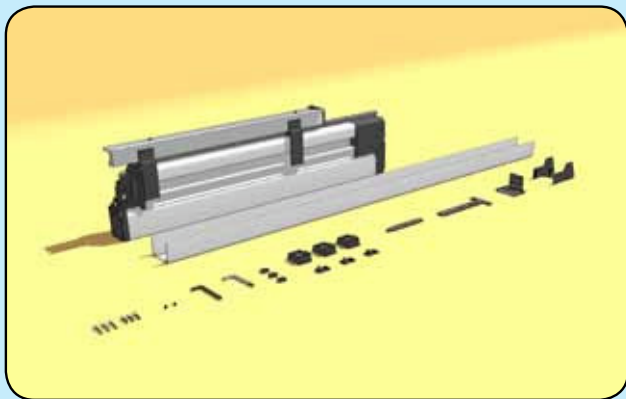



La versione a due battenti è composta da DUE zanzariere ad un battente.
Fare riferimento all'indice di pg. 4.

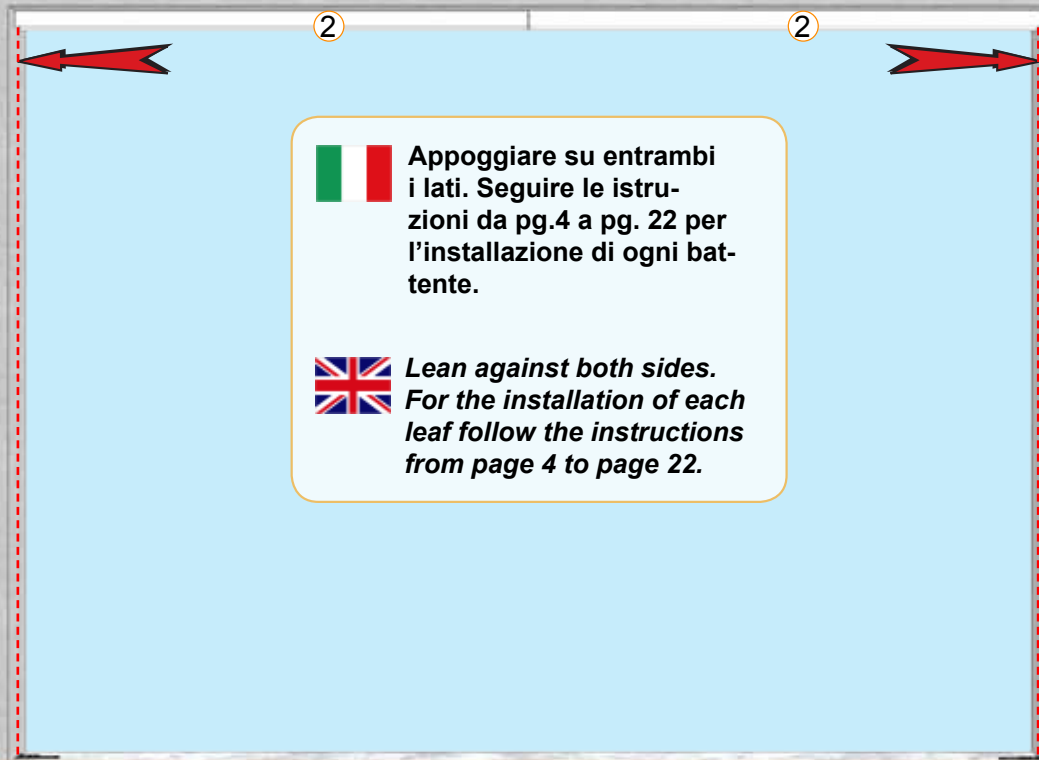

The double leaf version is composed of two single leaf screen, please refer to page 4 in the index.



 **Appoggiare su entrambi i lati. Seguire le istruzioni da pg.4 a pg. 22 per l'installazione di ogni battente.**

 ***Lean against both sides. For the installation of each leaf follow the instructions from page 4 to page 22.***

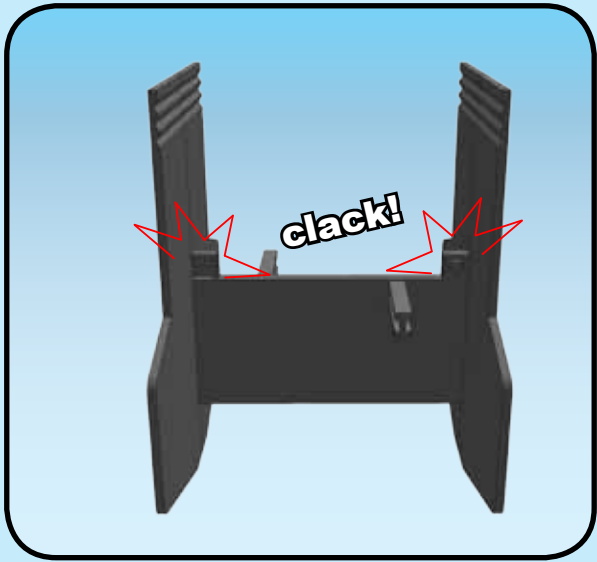
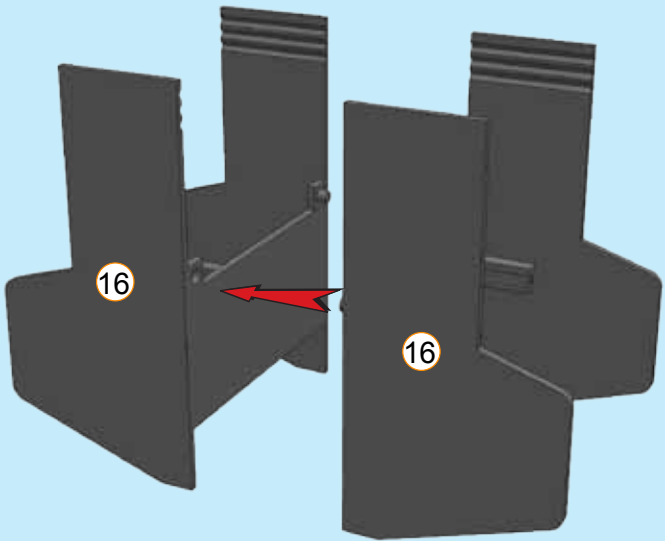

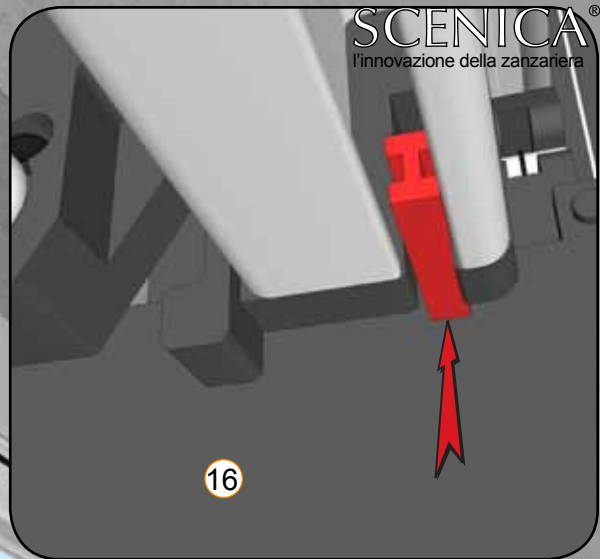
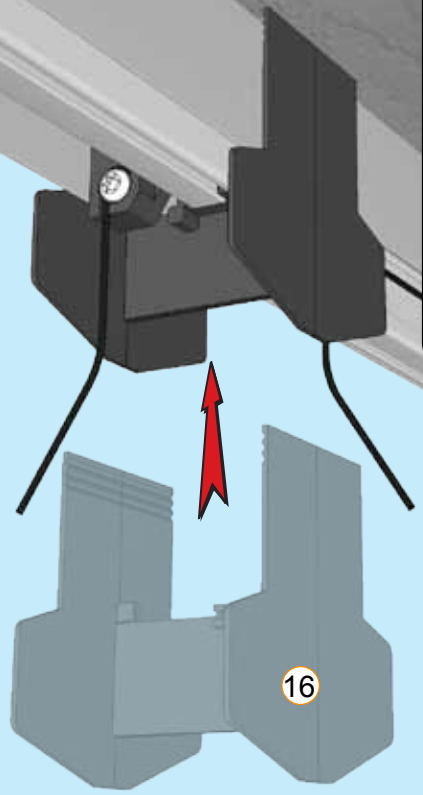

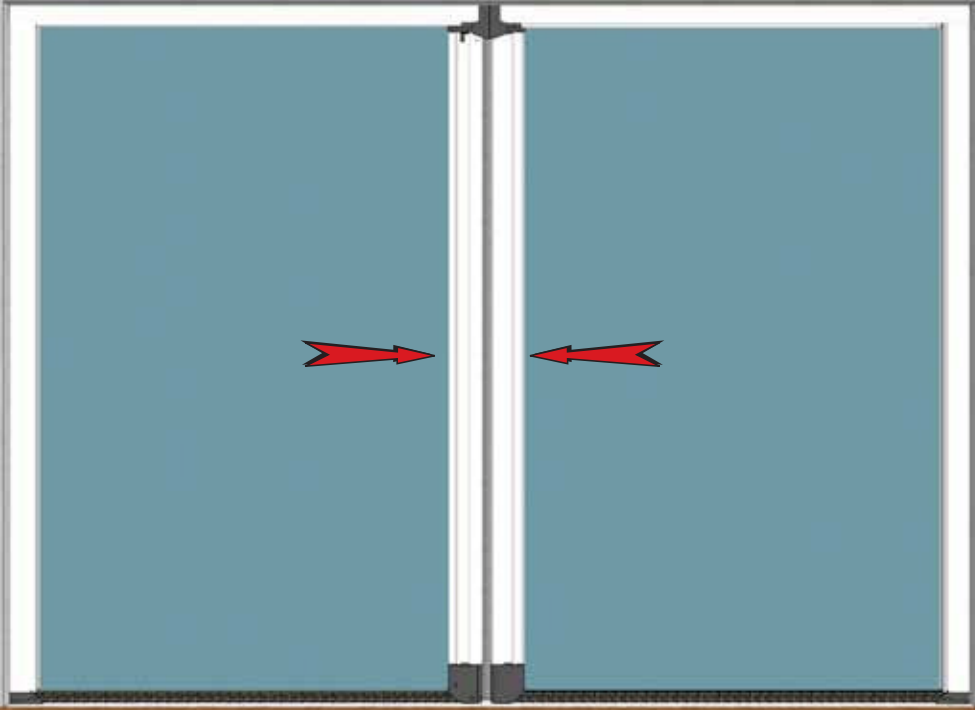

ok!

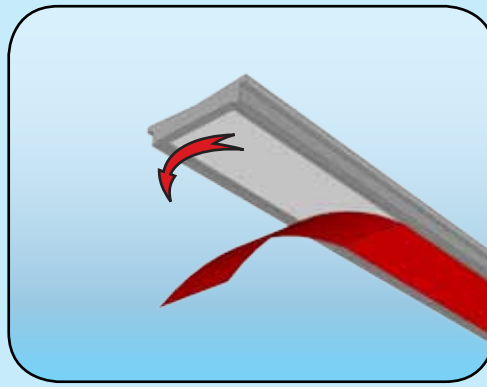



**Profilo di scorrimento
opzionale.**

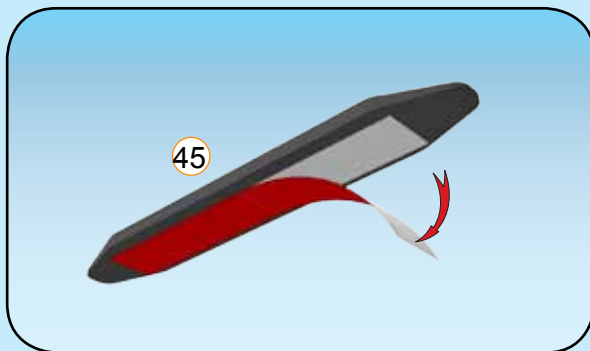

Optional sliding profile.



 **Accessorio complementare.
Installazione a discrezione.**

 **Additional component.
Optional installation**

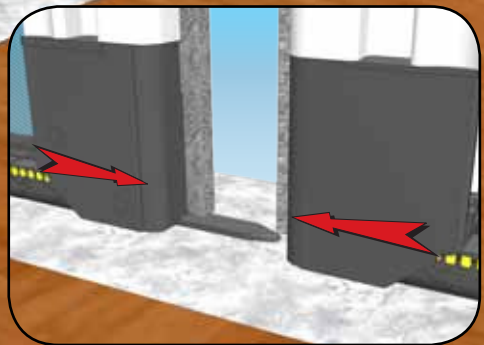
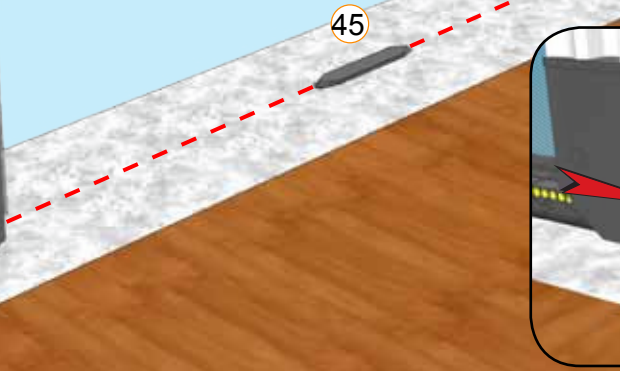

Versione ad incasso
Built-in-guide version

2

21

50mm



In assenza di appoggio alla parete utilizzare il tappo compensatore.



If you can't lean the profiles against the wall, please use the adjuster caps.

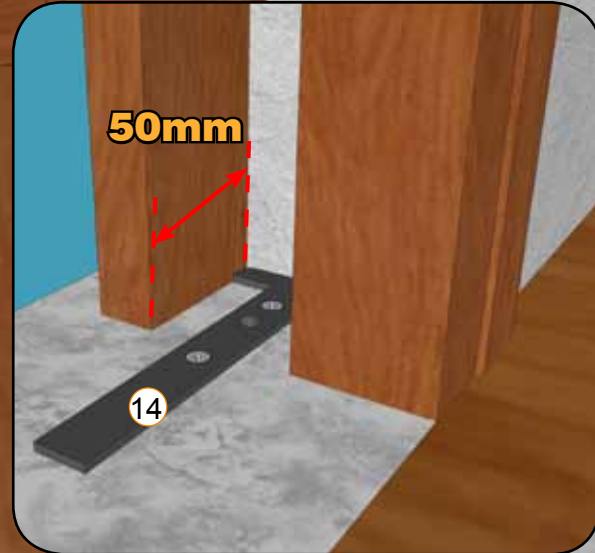

50mm

14

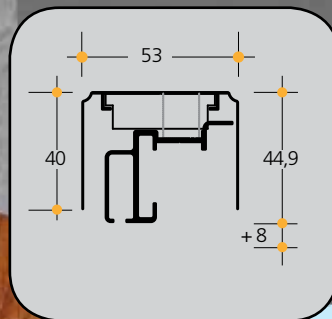

40mm

2



Inserire degli spessori in legno.



Shim with wood pieces.

Installazione ad incasso



Inserire degli spessori in legno.



Shim with wood pieces.

40mm



Profilo a "U" in dotazione.



Supplied "U" shaped profile.

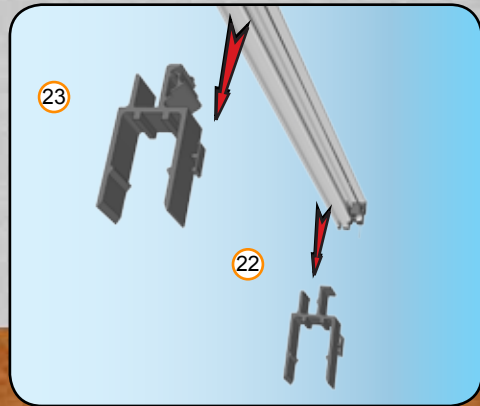
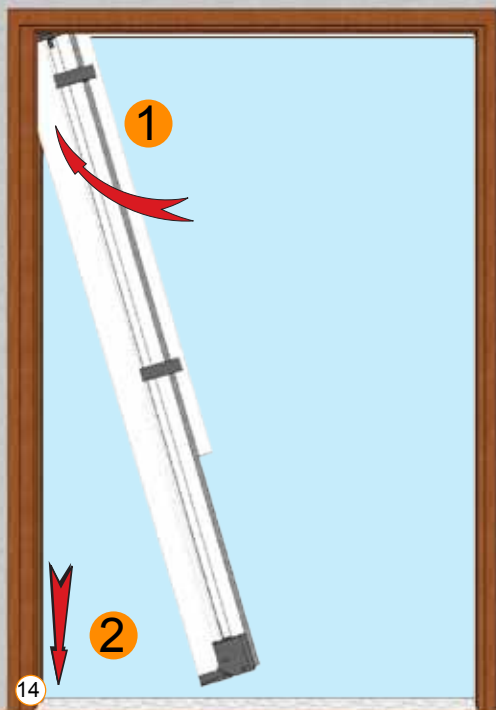



Installazione ad incasso

Built-in-guide installation 37



Assicurarsi che il cordino fino inferiore sia libero di muoversi.



Make sure that the thin lower cord is free to move.



Assicurarsi che il cordino grosso sia inserito correttamente nella gola della puleggia.



Make sure that the thick cord is in the groove of the pulley.

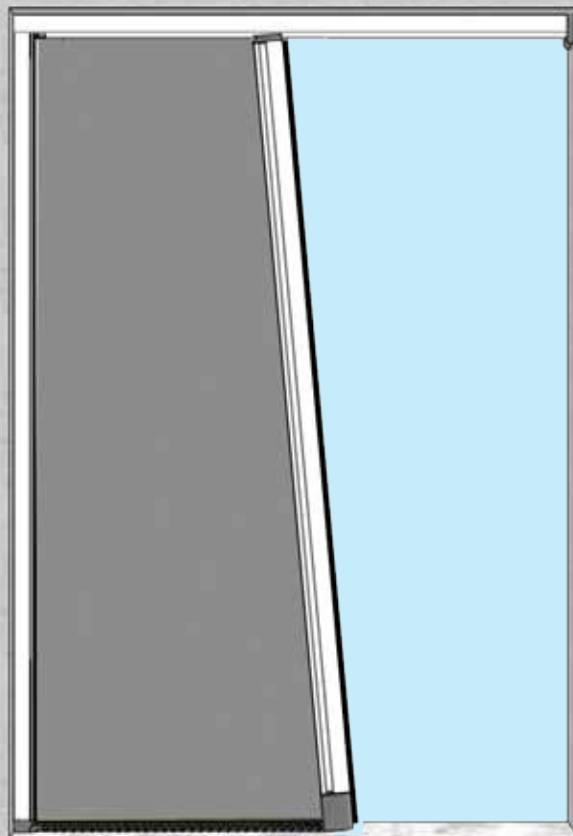

 **Problema 1**

 **Problem 1**

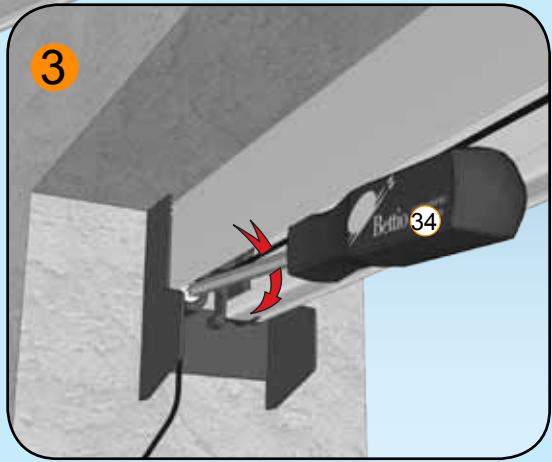
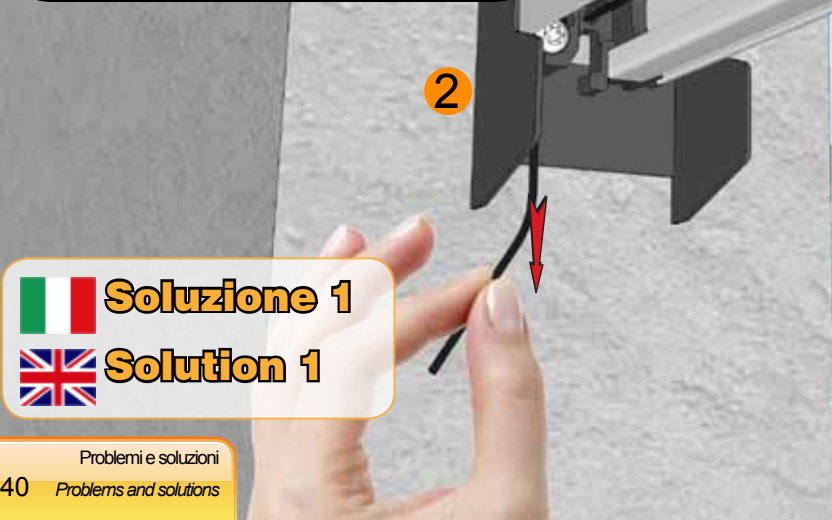
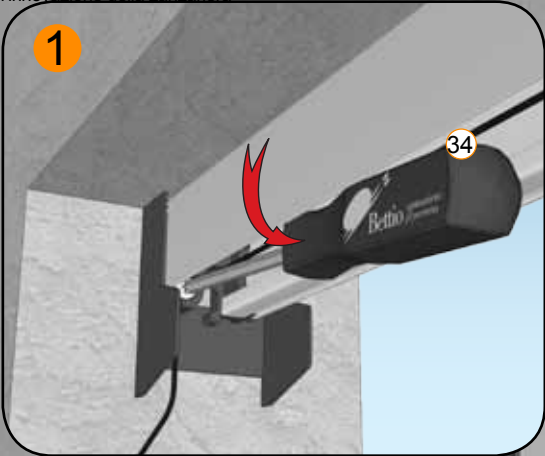

Soluzione 1



Solution 1

NO



Deve passare almeno un foglio di carta sotto la maniglia. Problematica valida anche per la versione a due battenti.



At least a sheet of paper must pass underneath the handle-bar. Problem also valid for the two-leaves version.



Problema 2



Problem 2

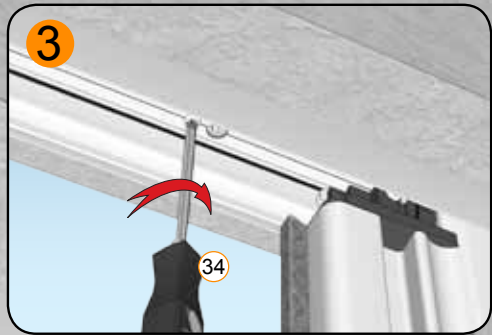
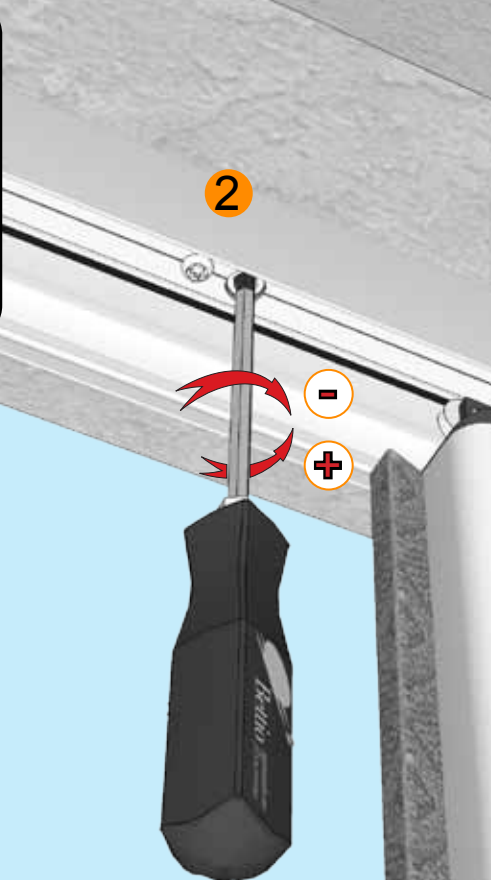
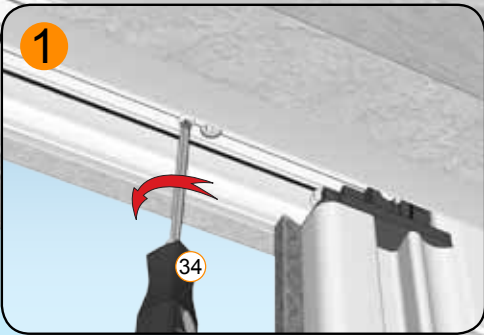

 **Soluzione 2**
 **Solution 2**

ok!

 **Soluzione 2**

 **Solution 2**

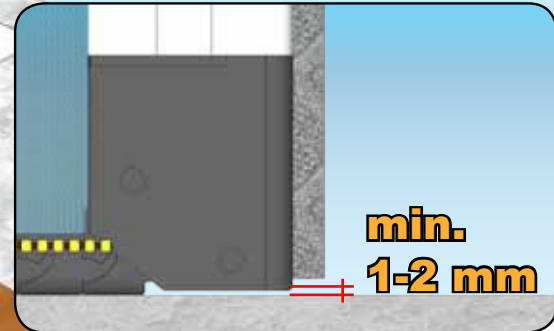



NO



Problema 3



Problem 3

ok!



Nel caso in cui la rete esca accidentalmente dalla sua sede, reinserirla delicatamente con l'aiuto delle mani, prima di riavvolgerla nel cassetto.



If the mesh goes accidentally off rail, insert it again gently by hands before closing the screen.



Soluzione 3



Solution 3

 **Aspirare delicatamente la rete e le parti esposte alla polvere.**

 ***Vacuum the mesh and the areas exposed to dust.***

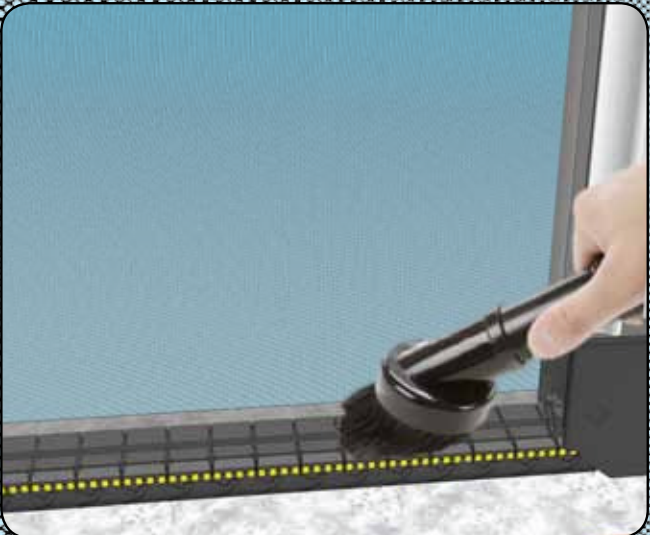

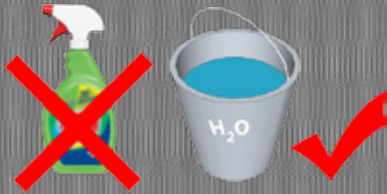

Pulire con un panno umido di soluzione neutra.

Per ottenere risultati ottimali raccomandiamo l'uso dei Prodotti per la Pulizia & Manutenzione delle Zanzariere Bettio, studiati appositamente per garantire il massimo delle prestazioni nel tempo.



Clean only with a wet cloth and neutral solution.

For the best results we suggest you to use Bettio's Flyscreens Products for Cleaning and Maintenance: they are expressly studied to grant you the maximum performance in time.



KIT PULIZIA/MANUTENZIONE ZANZARIERA CLEANING/MAINTENANCE FLYSCREEN SET



SPRAY ARIA COMPRESSA

Rimuove con facilità i residui di lavorazione che possono prodursi in fase di assemblaggio. Si utilizza anche per la pulizia periodica della guida mobile e della rete.



COMPRESSED AIR SPRAY

It removes easily all traces made during the assembling process. You can also use it for the periodical cleaning of mesh and sliding rail.



SPRAY LUBRIFICANTE

Indispensabile per il corretto assemblaggio, nonché l'installazione e la manutenzione di tutti i prodotti SCENICA®. La sua speciale miscela evita l'accumulo dello sporco all'interno dei meccanismi di movimentazione e mantiene il funzionamento fluido e silenzioso.



LUBRICANT SPRAY

Indispensable for a good assembling, installation and maintenance of SCENICA® products. The special mix of the lubricant prevents to gather dirt inside the handling mechanisms and also keeps the functioning silent and fluid.



SPRAY PULITORE ALLUMINIO/RETE

Studiato specificatamente per la pulizia dei profili in alluminio e della rete, questo prodotto elimina tutte le impurità senza intaccare la vernice, mantenendo la zanzariera perfettamente integra nel tempo.



ALUMINIUM/MESH CLEANER SPRAY

Expressly studied for the cleaning of mesh and aluminium profiles, this product removes all the impurities without damaging the coating and then keeps the flyscreen perfectly clean.



BETTIO PROFESSIONAL KIT

SCENICA®
l'innovazione della zanzariera



VALIGIA INSTALLAZIONE/MANUTENZIONE ZANZARIERA

Una pratica valigia per l'installatore che contiene uno spray lubrificante, uno spray aria compressa, uno spray pulitore alluminio/rete, un cacciavite TORX e un cacciavite esagonale.



INSTALLATION / MAINTENANCE FLYSCREEN BAG

A practical bag dedicated to the installers. Inside you can find: a lubricant spray, a compressed air spray, a aluminium/mesh cleaner spray, a TORX screwdriver and an hexagonal screwdriver.

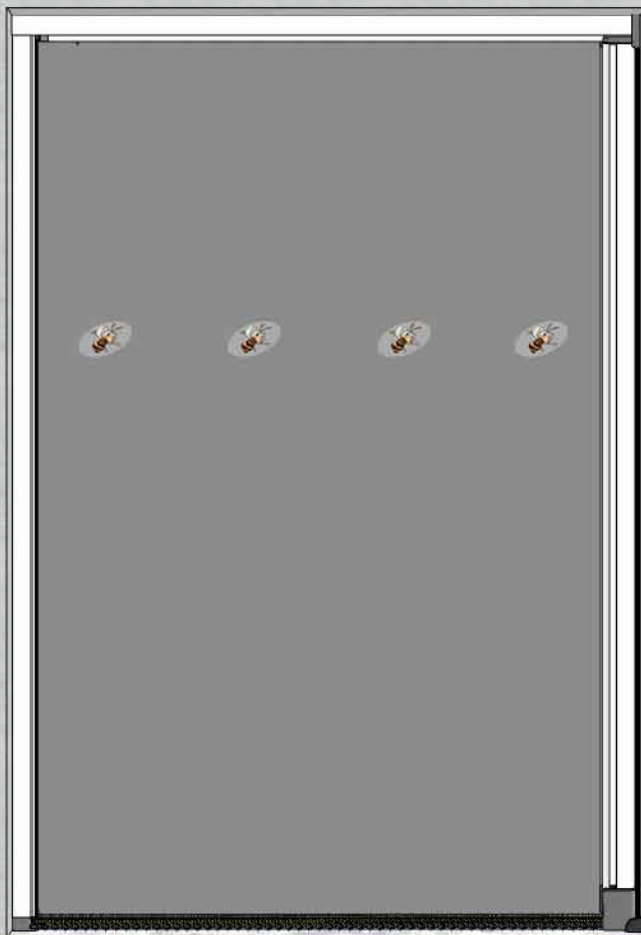
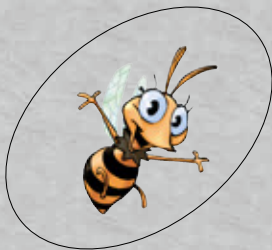

160cm



**Per la vostra sicurezza:
apporre gli speciali
adesivi segnaletici ad
una altezza di 160 cm.**



***For your safety: please
put the stickers at 160
cm height.***



DICHIARAZIONE DI CONFORMITÀ
ai sensi della Direttiva Europea 2006/42/CE

La società BETTIO Service S.p.A. con sede in Via dell'Artigianato n°9, 30020 Marcon (Venezia), nella persona del Sig. Loris Bettio nella sua qualità di Presidente espressamente delegato a questo scopo e sotto la sua propria esclusiva responsabilità,

D I C H I A R A

che la persona autorizzata a costituire il fascicolo tecnico, è l'Ing. Franco Zannoner reperibile presso l'Azienda;
che la zanzariera con rete in fibra di vetro nel modello SCENICA®, laterale senza barriere da 50, in varie misure come specificato nel Catalogo in vigore,

È C O N F O R M E

ai requisiti delle seguenti Direttive Europee:

- 2006/42/CE
- EN 13561:2004 "tende da sole" requisiti di funzionamento e sicurezza. Resistenza al vento NPD.
- EN 14201:2004 Resistenza alle operazioni ripetute.
- EN 13120:2004 Tende tecniche - requisiti di funzionamento e sicurezza.
- UNI EN 349/94 Spazi minimi per evitare lo schiacciamento di parti del corpo.
- UNI EN ISO 12100-1/2005, UNI EN ISO 12100-2/2005 Sicurezza del macchinario. Principi generali di progettazione.
- UNI EN 1050/98 Principi per la valutazione del rischio.

nonchè alle loro modifiche e aggiornamenti ed alle disposizioni che ne attuano il recepimento all'interno dell'Ordinamento Legislativo Nazionale del paese di destinazione e di utilizzo della zanzariera.

Firma del delegato
BETTIO SERVICE S.p.A.
Presidente Loris Bettio

Marcon (VE), 29 dicembre 2009

ISTRUZIONI D'USO E MANUTENZIONE (ISTRUZIONI ORIGINALI)

1. SCOPO

Queste istruzioni sono rivolte a chi utilizza la zanzariera o la tenda come installatore, manutentore, proprietario o utente. Con questo strumento la BETTIO SERVICE SPA intende fornire al Cliente uno strumento di supporto per un uso più consapevole e corretto dei sistemi di zanzariere e tende filtranti o oscuranti installati, al fine di un'ottimizzazione delle loro prestazioni. E' quindi consigliato per un corretto e vantaggioso utilizzo del sistema tenere disponibili le presenti note ai fini di garantire una rapida consultazione ogni qualvolta le circostanze lo rendano necessario. Esse sono comunque supportate dal Manuale d'Uso e Manutenzione e dal Fascicolo Tecnico disponibili in Azienda.

2. CAMPO DI APPLICAZIONE

Le presenti istruzioni si riferiscono al modello SCENICA®, laterale senza barriere da 50, per la quale sono coerentemente adattati i contenuti.

3. RIFERIMENTI

Le presenti istruzioni, sono state redatte, secondo il punto 1.7.4 della Direttiva 2006/42/CE e tenendo conto delle normali condizioni di uso della macchina al fine di informare, unitamente alle altre istruzioni per l'uso apposte sulla macchina, gli operatori/utilizzatori anche sui rischi residui che la stessa presenta.

4. USI PREVISTI

La funzione del sistema zanzariera installato è esclusivamente quella di dare protezione contro l'intrusione di insetti e piccoli animali negli ambienti da proteggere.



Ogni impiego diverso da quello indicato deve essere considerato improprio, e pertanto vietato, in quanto le relative condizioni di esercizio non sono state considerate nell'analisi dei rischi condotta dal fabbricante e per i quali potrebbero non essere presenti protezioni specifiche. E' vietato appoggiarsi alla rete. E' vietato lasciare la barra maniglia senza accompagnarla fino al totale riavvolgimento della rete o del tessuto.

Quando la velocità del vento raggiunge i 20 km/h è necessario chiudere la zanzariera o la tenda.

L'uso improprio assolve da ogni responsabilità il costruttore stesso, per eventuali danni causati a persone o cose.

Il mancato rispetto delle condizioni d'uso fa decadere automaticamente qualsiasi tipo di garanzia data dal produttore.

5. REQUISITI DELL' OPERATORE

L'uso normale della zanzariera è consentito ad operatori non professionisti purchè di età superiore ad anni 12.

Le operazioni di installazione, riparazione e manutenzione straordinaria, devono essere effettuate da personale tecnico qualificato.

6. RACCOMANDAZIONI PER L'INSTALLAZIONE

L'installazione deve essere eseguita nel pieno rispetto del D.Lgs. 81/2008 e delle successive modifiche e integrazioni, per tutto ciò che attiene la sicurezza delle persone.

Il committente e l'installatore sono rispettivamente responsabili ai sensi della legge vigente, in materia di sicurezza.

E' necessario controllare, prima dell'utilizzo, che trabattelli, ponteggi, scale e tutti i dispositivi di protezione individuale (imbracature, cinghie di sicurezza, guanti, scarpe di sicurezza, elmetti, ecc.), eventualmente utilizzati, siano a norma ed in buono stato. Utilizzare i mezzi d'imbracatura adeguati.

Nel caso gli installatori siano più di uno, è necessario coordinare i lavori, definire i compiti e le responsabilità. Gli operatori devono comportarsi in conformità alle istruzioni di sicurezza ricevute (POS). Nel caso in cui il prodotto debba essere montato ad un piano elevato rispetto a quello di terra, è necessario delimitare e presidiare l'area durante la salita al piano del prodotto in modo che nessuno possa trovarsi sotto l'eventuale carico sospeso. **L'imballo del prodotto contiene le istruzioni di montaggio, d'uso, manutenzione e garanzia: l'installatore deve accertarsi che siano consegnate, previa lettura e commento, all'utilizzatore finale.**

7. INSTALLAZIONE DELLA STRUTTURA MECCANICA



Una installazione non corretta può essere causa di infortuni alle persone. Leggere attentamente le istruzioni per un fissaggio corretto del prodotto in modo da evitare rischi di caduta dello stesso.

E' necessario verificare lo stato della struttura sulla quale viene effettuato l'ancoraggio/fissaggio della zanzariera.

In realtà lo sforzo dinamico cui il telaio dovrà resistere con la zanzariera completamente svolta dal cassonetto, è quello del vento che soffia a 130 km/h. In presenza di mattoni forati utilizzare tasselli espansibili con collante chimico di adeguate dimensioni. Nel caso non siano rispettati i requisiti di resistenza necessari ad un fissaggio in sicurezza, aumentare il numero di tasselli e viti. La scelta delle viti e dei tasselli di ancoraggio, dipende anche dallo stato e dalla natura della struttura muraria/metallica/serramento sulla quale si effettua l'installazione/fissaggio. I tasselli e le viti non sono forniti con il prodotto. Fare attenzione nella manipolazione del prodotto: gli avvolgitori sono montati con molle cariche. Le istruzioni di posa in opera, sono descritte nel foglio contenuto nell'imballo. L'eventuale attività di sigillatura sarà eseguita con resina siliconica neutra.

Quando la velocità del vento raggiunge i 20 km/h è necessario chiudere la zanzariera.

8. MANUTENZIONE

8.1 Manutenzione ordinaria

Data l'alta qualità dei materiali impiegati nella costruzione della zanzariera, non è prevista alcuna manutenzione ordinaria tranne l'eventuale pulizia della rete per salvaguardarla dalla formazione di muffe causate dal deposito di polveri o altro materiale sulla stessa.

La rete, deve essere controllata visivamente almeno 2 volte all'anno: in primavera prima dell'utilizzo per la stagione estiva ed in autunno prima della chiusura invernale. La pulizia della rete può essere effettuata con aspirazione della polvere, oppure con spugna o panno umido utilizzando acqua tiepida.

Fare asciugare la rete dopo la pulizia e prima dell'avvolgimento. Per la pulizia, NON utilizzare solventi-ammoniaca-idrocarburi.

ATTENZIONE: la pulizia con scale, trabattelli o altro è riservata a personale specializzato che dovrà eseguire le operazioni nel rispetto delle norme di sicurezza e dovrà utilizzare i dispositivi di protezione individuale quali imbracature di sicurezza con fune di trattenuta (vedi D.Lgs. 81/2008).

8.2 Manutenzione straordinaria

ATTENZIONE: tutte le operazioni di manutenzione straordinaria devono essere effettuate da personale professionalmente qualificato ed addestrato: pertanto è necessario richiedere l'intervento dello specialista. Vedere le istruzioni di installazione di posa in opera per l'eventuale smontaggio della zanzariera, o di parti di essa.

In presenza di strappi sulla rete, anche di piccole dimensioni, è necessario provvedere alla sua sostituzione.

Usare parti di ricambio originali, pena la decadenza della garanzia.

9. GARANZIA

La garanzia si applica in relazione ai contenuti del D.Lgs. n.24 del 02.02.2002. La durata della Garanzia è di 24 mesi (o maggiore quando esplicitamente indicato) per le Persone fisiche che acquistano il prodotto per scopi che possono considerarsi estranei alla loro attività professionale (Cliente privato finale). E' di 12 mesi se il prodotto è fatturato ad un'Impresa o Professione soggetto di IVA.

La garanzia si riconosce sul funzionamento del prodotto e sui materiali che lo compongono, esclusi i danni indiretti. Non vengono coinvolti nel concetto di garanzia eventuali costi sostenuti per raggiungere il luogo dove si trova il prodotto oggetto di garanzia ed eventuali costi di installazione o rimozione.

Poiché è prassi utilizzare il documento fiscale di vendita per dare validità e data certa alla garanzia, lo stesso documento ne determinerà la durata.

9.1 Norme per la validità della Garanzia

Rispettare l'uso consentito del prodotto. Rispettare le norme d'uso e manutenzione. La garanzia sarà valida solo se accompagnata dal documento di vendita, comprovante la data d'acquisto. L'installazione, così come la manutenzione obbligatoria, dovrà essere effettuata solo ed esclusivamente da un installatore specializzato; entrambe dovranno essere comprovate con il documento fiscale relativo a questa garanzia.

9.2 Decadimento della Garanzia.

- Uso improprio del prodotto in occasione di vento, pioggia, grandine, neve e/o altri eventi combinati.
- Cedimento della parte dove il prodotto è stato ancorato.
- Manomissione del prodotto; installazione, smontaggio, manutenzione non effettuati da installatore specializzato o non effettuati secondo le norme e le istruzioni di montaggio.
- Mancata manutenzione obbligatoria entro i termini stabiliti.
- Uso di parti di ricambio non originali BETTIO SERVICE SPA.
- Rimozione od occultamento dell'etichetta identificativa BETTIO SERVICE SPA, per cui la rintracciabilità del prodotto non risulta possibile.

Per altre specifiche esclusioni dalla Garanzia, si fa riferimento alle eventuali note specificate dall'Azienda. Per qualsiasi controversia, si elegge quale unico foro competente quello di Venezia.

10. IMBALLO MOVIMENTAZIONE E TRASPORTO

La zanzariera è imballata con film estensibile MDT per proteggere e bloccare l'intelaiatura durante il trasporto, se effettuato con i nostri mezzi o ritirato direttamente dal cliente presso la nostra sede. Se invece il trasporto della zanzariera avviene tramite un corriere allora il prodotto viene imballato con film estensibile MDT e poi inserito in scatole di cartone riempite a loro volta con sacchetti d'aria al fine di proteggere e bloccare la struttura durante la movimentazione ed il trasporto. Date le dimensioni e la forma del prodotto, è necessario, oltre la misura in lunghezza di 240 cm, effettuare la movimentazione manuale in due persone.



L'imballo contiene le istruzioni di montaggio, d'uso, manutenzione e garanzia: il montatore deve accertarsi che siano consegnate, previa lettura e commento, all'utilizzatore finale.

Non lasciare alla portata dei bambini i materiali d'imballo, possono costituire fonte di pericolo per gli stessi.

11. ELENCO DEI RISCHI

11.1 Installazione: Adottare tutte le precauzioni previste in cantiere con particolare riguardo a quelle riguardanti i rischi di caduta.

11.2 Rischi inerenti l'utilizzo e la normale manutenzione.

Prodotti con molla di richiamo:

-Pericolo di caduta durante le operazioni di pulizia del telaio, del tessuto e/o della rete: evitare di sporgersi o farlo solo utilizzando attrezzature adeguate

11.3 Rischi inerenti la manutenzione/riparazione:

a) Pericolo di urto durante le operazioni di carico/scarico della molla

b) Pericolo di non corretto ripristino della zanzariera durante il cambio della rete

c) Pericolo derivante dal mancato utilizzo di attrezzature e DPI non marchiati CE

11.4 Pericolo di inciampo sulla guida mobile dei prodotti Scenica®: apporre segnaletica di avvertimento

11.5 Pericolo di inciampo sulla guida inferiore della porta con apertura laterale: apporre segnaletica di avvertimento

11.6 Rischi inerenti la dismissione: la dismissione del prodotto deve essere eseguita in base alle norme al momento in vigore

11.7 Il livello di rumore è inferiore a 70 dB(A)

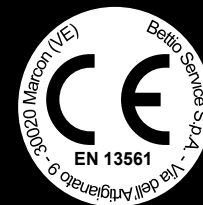

DECLARATION OF CONFORMITY
in accordance with European Directive 2006/42/EC

The company BETTIO Service S.p.A. with registered office in Via dell'Artigianato No. 9, 30020 Marcon (Venezia), as represented by Mr Loris Bettio in his capacity as Chairman expressly delegated for this purpose and under his own responsibility,

DECLARES

that the person authorized to create the technical file is the engineer Mr Franco Zannoner who can be contacted at the Company;
that the flyscreen with fibreglass mesh - SCENICA® - lateral 50 without barriers, in the various sizes as specified in the current catalogue,

COMPLIES

with the requirements of the following European Directives:

- 2006/42/EC
- EN 13561:2004 "External blinds" performance requirements including safety. Wind resistance NPD.
- EN 14201:2004 Resistance to repeated operations.
- EN 13120:2004 Internal blinds – performance requirements including safety.
- UNI EN 349/94 Minimum gaps to avoid crushing parts of the human body.
- UNI EN ISO 12100-1/2005, UNI EN ISO 12100-2/2005 Safety of machinery. General principles for design.
- UNI EN 1050/98 Principles for risk assessment.

It also complies with the amendments and updates of the above Directives and the provisions that implement their assimilation into the National Legal System of the country of destination and installation of the insect screen.

Signature of person empowered
Chairman Loris Bettio

Marcon (VE), 29 December 2009

INSTRUCTIONS FOR USE AND MAINTENANCE (TRANSLATION OF ORIGINAL INSTRUCTIONS)

1. PURPOSE

These instructions are intended for those who use the flyscreen, such as the installer, maintenance person, owner or user. With this instruction booklet BETTIO SERVICE SPA wishes to provide Customers with a tool for better, correct use of installed flyscreens and light filtering or blackout blinds, so as to optimize their performance. For correct and best use of the system it is therefore recommended that these notes be kept to hand for quick reference whenever required. Supplementary information may be had in the Operating and Maintenance Guide and the Technical File available at the Company's offices.

2. SCOPE

These instructions refer to the following model: SCENICA® lateral 50 without barriers, for which the contents are suitably adapted.

3. REFERENCES

These instructions have been prepared, as have other instructions for use applied to the product, in accordance with point 1.7.4 of Directive 2006/42/EC taking into consideration normal conditions of use of the product, to inform operators and users also of the residual risks that the product presents.

4. ENVISAGED USE

The function of the installed flyscreen system is solely to provide protection against the intrusion of insects and small animals into the environments to be protected.



Any use other than has been described above is considered incorrect and is therefore forbidden, since the relative working conditions will not have been taken into account when the manufacturer analysed the risks and consequently there could be no specific protective devices fitted. Do not lean against the mesh. Do not let go of the handle rail until the mesh is fully rewound.

Misuse relieves the manufacturer from all liability for any injury to persons or damage to property.

Failure to comply with the conditions of use automatically invalidates any type of warranty given by the manufacturer.

5. OPERATOR REQUIREMENTS

Normal use of the flyscreen is allowed for non-professional users provided they are aged 12 and over. Installation, repair and extraordinary maintenance must be carried out by qualified technical personnel.

6. RECOMMENDATIONS FOR INSTALLATION

Installation must be carried out in full compliance with Italian Legislative Decree 81/2008 and subsequent amendments and additions for all that concerns the safety of persons. In accordance with current laws, the client and the installer are both responsible with regard to safety. Before using any equipment such as drills, screwdrivers, work platforms, scaffolding, steps and all personal protection equipment (slings/harness, safety belts, gloves, safety shoes, helmets, etc.), check that they are in compliance with regulations and in good condition. Use suitable slings or harnesses. If there is more than one installer, the work must be coordinated and the tasks and responsibilities defined. Users must abide by the applicable safety instructions received (POS). If the product is to be installed on any floor above ground level, the area must be cordoned off and supervised while the product is being raised to the relevant floor so that no person is under any suspended load.

7. INSTALLATION OF THE MECHANICAL STRUCTURE

Incorrect installation can cause injury to persons. Carefully read the instructions for correct fixing of the product so that there is no risk of it falling down.



The state of the structure on which the flyscreen will be fixed must be checked on the basis of the dynamic stress that the frame must withstand with the flyscreen fully unwound from the cassette, and that is a wind speed of 130 km/h. With hollow bricks use suitably sized expansion plugs with chemical adhesive.

If the resistance requirements necessary for safe fixing are not satisfied, increase the number of wall plugs and screws. The screws and wall plugs also depend on the state and the nature of the structure, masonry/metal/wood window/door frame, onto which the installation/fixing is to be carried out. Wall plugs and screws are not supplied with the product. Take care when handling the product: the winder mechanisms are mounted with loaded springs. The instructions for installation are described on the sheet contained in the pack. Any sealing must be done with neutral silicone resin. **The flyscreen must be closed when the wind speed reaches 20 km/h.**

8. MAINTENANCE

8.1 Routine maintenance

Given the high quality of the materials used in making the flyscreen, no routine maintenance is envisaged other than cleaning the mesh to protect it against the formation of mould/mildew caused by dust or other material being deposited on them. The mesh must be visually inspected at least twice a year; a mesh screen should be checked in spring before being used for the summer and in autumn before packing it up for the winter.

The mesh may be cleaned with a vacuum cleaner; the mesh may also be cleaned with a sponge or cloth dampened with lukewarm water. Let the mesh dry thoroughly after cleaning before winding it up. Do NOT use solvents, ammonia or hydrocarbons for cleaning.

CAUTION: cleaning carried out using steps, platforms or such must only be done by specialised personnel working in conformity with safety regulations and who must use suitable personal protective equipment such as body harnesses with separate safety line (see Italian Legislative Decree 81/2008).

8.2 Extraordinary maintenance

CAUTION: only professionally qualified and trained personnel may carry out extraordinary maintenance: it is therefore necessary to request the service of a specialist. If the flyscreen or any part of it needs to be dismantled, see the installation instructions. If the mesh is torn, however small the tear, it must be replaced.

Only use original spare parts otherwise the warranty is invalidated.

9. WARRANTY

The warranty is applicable in relation to the contents of Italian Legislative Decree No. 24 of 02.02.2002. The Warranty is for 24 months (or more when explicitly indicated) and covers natural persons who purchase the product for purposes that may be considered unrelated to their professional activity (private end customer). The warranty is for 12 months if the product is invoiced to a Company or Professional office subject to VAT.

The warranty covers any part or parts which are shown to be defective due to faulty material or workmanship. The company will not be responsible for any incidental or consequential damage or injury. The warranty does not cover any costs incurred to reach the place where the product is installed nor any costs for installation or removal. As is accepted practice, the original invoice or receipt is evidence of the date of purchase and therefore of the validity and duration of the warranty.

9.1 Rules for the Warranty to be valid

- Comply with the allowed use of the product.
- Comply with the instructions for use and maintenance.

- The warranty will only be valid if accompanied by the invoice or receipt giving evidence of the date of purchase.
- Only a specialised installer must carry out installation and compulsory maintenance, proof of which must be shown by means of the taxation document with regard to this warranty.

9.2 Invalidation of the Warranty.

- Misuse of the product in the presence of wind, rain, hail, snow or other combined events.
 - Collapse of the part where the product has been anchored.
 - Tampering with the product; installation, dismantling and maintenance not carried out by a specialised installer or not carried out in accordance with regulations and installation instructions.
 - Failure to have compulsory maintenance carried out within the established times.
 - Use of other than BETTIO SERVICE SPA original spare parts.
 - Removal or concealment of the BETTIO SERVICE SPA identification label making traceability of the product impossible.
- For other specific exclusions from the Warranty, see any notes specified by the Company. For all and any dispute the sole place of jurisdiction is Venice.

10. PACKAGING, HANDLING AND TRANSPORTATION

The flyscreen is packed in stretch film to protect and wedge the framework during transportation, if delivered with our means of transport or collected directly by the customer from our place of business.



If the flyscreen is transported by a carrier, then the product is packed with stretch film and then inserted into cardboard boxes filled with airbags to protect and wedge the structure during handling and transportation. Given the size and shape of the product, when it is longer than 240 cm it must be handled by two persons. The packaging contains the instructions for installation, use and maintenance as well as the warranty; the installer must ensure that they are read over, explained and then given to the end user.

Keep the packaging materials out of reach of children, since they can be a source of danger.

11. LIST OF RISKS

11.1 Installation: take all the necessary precautions on site especially in respect of the risks of fall.

11.2 Risks related to use and routine maintenance.

Products with return spring:

- danger of fall during cleaning of mesh: avoid leaning out of windows or only do so using suitable equipment.

11.3 Risks related to maintenance/repair:

- a) danger of impact during spring loading/release operations
- b) danger of incorrect refitting of the flyscreen after mesh replacement
- c) danger due to failure to use equipment and to PPE that do not bear the EC mark

11.4 Danger of tripping over chain elements: place warning signs

11.5 Danger of tripping over guide for door with side opening: place warning signs

11.6 Risks related to disposal: the product must be disposed of in accordance with rules and regulations currently in force

11.7 The noise level is below 70 dB(A)

Gentile Cliente,

Le ricordiamo che il mondo delle zanzariere BETTIO è vasto e molto ben assortito e comprende anche tanti altri modelli per tutti gli usi ed esigenze della Sua casa. La invitiamo ad approfondire la conoscenza dei nostri prodotti che offrono molteplici soluzioni anche all'applicazione della zanzariera nei vani finestra. Ed inoltre la linea LIVING, la tenda oscurante o filtrante a misura che protegge dal sole ed arreda la casa e l'ufficio, e il cui catalogo comprende numerosi tipi di tessuti – tra cui alcuni assai tecnici – che consentono la personalizzazione con foto e loghi o l'isolamento anche termico degli ambienti.

Per ulteriori informazioni può rivolgersi presso il Suo rivenditore di fiducia.



Dear Customer,
We remind you that the world of BETTIO insect screens is pretty big and well assorted and includes also many more models for every use and need of Your home. We invite you to deepen your knowledge of our products that offer several solutions also for the installation of flyscreens in window rooms. Moreover, we suggest you the line called LIVING, a black-out and shading roller blinds range, made-to-measure, that protects from the sunlight and fits your home and office. The LIVING catalogue includes various fabrics – some of them with very technical features – that enable you to customize the screens with photos and logos, or the thermic isolation of the rooms.

For further informations, please, contact your BETTIO area manager

www.bettio.it



Visita il sito Bettio!

Potrai scaricare i cataloghi più aggiornati e le istruzioni, visionare i modelli di ultimissima generazione, essere informato sulle news dell'Azienda: fiere, eventi e curiosità. Nella sezione Media Video la multimedialità è di casa: una ricca selezione di eventi, convention, fiere, istruzioni di montaggio dettagliate e video promozionali dei diversi prodotti, tutto a portata di un click!

Visit Bettio web site!

You can download updated catalogues and instructions sheets, look at the brand new fly-screen models, get informed about company's news (exhibitions, events and curiosities). Media Video section is home to many multimedia features: a rich selection of events, conventions, exhibitions, detailed instructions and promo videos of the products. You can get everything with a simple click!



Bettio, azienda leader nel settore delle zanzariere deve la sua evoluzione alla determinazione ed intraprendenza dei suoi fondatori. Negli anni 90, Bettio inizia la produzione in larga scala di zanzariere ed oggi, unita sotto un unico marchio **Bettio Zanzariere Flyscreens**, opera nel mercato internazionale in 2 divisioni: **Bettio Service**, dedicata alla produzione di zanzariere su misura e **Bettio Group**, orientata alla produzione di sistemi semilavorati per zanzariere.

Il successo non è casuale: Bettio fonda la sua mission su prodotti di eccellenza, sapiente mix di abilità tecnica, innovazione tecnologica, ricerca costante ed un team affiatato. Inoltre la capacità di coinvolgere la propria clientela in eventi entusiasmanti fanno della Bettio il Partner ideale per lo sviluppo dei propri progetti.

Bettio, leading manufacturer of insect screen systems, has evolved up to the present top market position thanks to the determination and enterprising attitude of the people who established it. Bettio starts its activity in a massive scale during the '90s and today, under the sole brand Bettio Zanzariere Flyscreens, the company sells its products in the international markets with its two branches: Bettio Service is committed to the manufacturing of made-to-measure items, whereas Bettio Group is focused on semi finished products. Company's success is not accidental: the grounds of Bettio's mission are top quality items resulting from a well balanced mix of technical skill, technological innovations, steady R&D process and a well working team. Moreover Bettio is able to involve the customers in exciting events, so it is the ideal Partner to develop their projects.



Prima nata del nostro Gruppo, **Bettio Service** si dedica con costante passione, alla produzione di zanzariere, oscuranti e filltranti su misura. Nonostante molto tempo sia passato dalla sua nascita, l'obiettivo di **Bettio Service** è rimasto assolutamente immutato: produrre zanzariere innovative, pratiche, funzionali e soprattutto di altissima qualità: oggetti che durino nel tempo e si armonizzino all'interno della casa come un vero articolo di arredamento.

Meccanismi brevettati, soluzioni innovative, sicurezza dei prodotti garantita dalla marcatura **CE**, precisione e puntualità delle consegne ed un efficace servizio di assistenza al cliente pre- e post-vendita: grazie a tutto questo i nostri prodotti sono oggi conosciuti ed apprezzati da milioni di italiani che hanno installato le zanzariere Bettio nelle loro case.



As the eldest branch of our Group, Bettio Service is committed with unchanged enthusiasm to the manufacturing of made-to-measure flyscreens and, black out/shading screens . Although a lot of time has passed since then, Bettio's goal is always the same: the manufacturing of innovative, handy and practical flyscreens, lasting for years and matching the home interiors as a real decoration item.

Patented mechanisms, innovative solutions, products safety granted by the CE branding, accurate and punctual deliveries, a good pre- and post-sales assistance: thanks to all of these factors our products are well known and appreciated by millions of Italians who have purchased and installed Bettio's flyscreens in their homes.



Bettio zanzariere
flyscreens
www.bettio.it

